

Operating Instructions

Valid as of: 01.11.2014• Please keep the manual for future reference!

for

Plastics

Foil, Paper

Textile Industries

Strip Processing

Lines

Rolling Mills

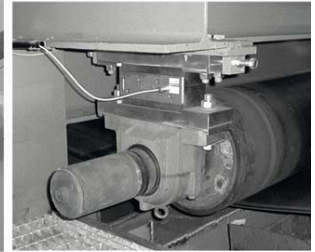

SCHMIDT · 1ST IN TENSIONMETERS WORLDWIDE



Mitglied
Member

	Page
Safety Instructions3
Force Measurement with Strain Gauges5
Web Tension Measurement Systems	
Functional Principle and Circuitry Versions5
Closed Loop Control6
Force Sensor Design and Areas of Application7
Selection Criteria7
Establishment of Nominal Force Rating8
Electrical Engineering of Force Measurement Systems	
Instructions for Electrical Devices9
Safety Instructions10
Cable Connections for Sensors	
Electrical connections11
Mounting of Web Tension Sensors	
Directions of Force12
Fixed /Floating Bearing13
Torque13
Mounting Instruction Bearing Support - Flange Design	
Fixed Bearing14
Floating Bearing15
Web Tension Calibration	
Commissioning16
Variant A - Loading with Reference Weight16
Variant B - Loading with Stroke Cylinder17
Inspection of Measuring Chain18
Operating of Web Tension Sensors	
Maintenance and Fault Notices19
Declaration of Conformity, CE Designation20
Manufacturer Declaration, Machinery Directive20
Terms and Definitions of Characteristics21
Correspondence, Repairs22



Absolutely consider characterized passages in the text with this reference!

Warranty and Liability

In principle, the supply of the device is subject to our "General Conditions of Sale and Delivery." These have been provided to the operating company on conclusion of the contract, at the latest.

Warranty:

- SCHMIDT tension meters are warranted for 12 months.

Parts subject to wear, electronic components and measuring springs are not covered by the warranty. No warranty or liability will be accepted for bodily injury or property damage resulting from one or several of the following causes:

- Misuse or abuse of the device.
- Improper mounting, commissioning, operation and maintenance of the device (e.g. verification interval).
- Operation of the device if any safeguards are defective or if any safety and protection precautions are not properly installed or not operative.
- Failure to comply with the notices in the Operating Instructions regarding transport, storage, mounting, commissioning, operation, maintenance and setup of the device.
- Any unauthorized structural alteration of the device.
- Insufficient inspection of device components that are subject to wear.
- Opening the device or improper repair work.
- Disasters caused by the effects of foreign objects or by force majeure.

Notices within the Operating Instructions

The fundamental prerequisite for the safe handling of this device and its troublefree operation is the knowledge of the basic safety notices and safety instructions.

These Operating Instructions contain the most important notices for the safe operation of the device.

These Operating Instructions, in particular the safety notices, must be observed by any person who works with the device. In addition, the local valid rules and regulations for the prevention of accidents must be complied with.

The representations within the Operating Instructions are not true to scale.

The dimensions given are not binding.

General indications of direction, such as FRONT, REAR, RIGHT, LEFT apply when viewing the front of the device.

Responsibilities of the Operating Company

In compliance with the EC Directive 89/655/EEC, the operating company agrees to only permit persons to work with the device who:

- are familiar with the basic regulations on industrial safety and accident prevention and who have been trained in handling the device.
- have read and understood the chapter on safety and the warning notices in these Operating Instructions and have confirmed this with their signatures.
- are examined regularly on their safe and conscientious working method.

Responsibilities of the Personnel

All persons who work with the device agree to perform the following duties before starting work:

- to observe the basic regulations on industrial safety and accident prevention.
- to read the chapter on safety and the warning notices in these Operating Instructions and to confirm with their signatures that they have understood them.

Informal Safety Measures

The Operating Instructions must always be kept on hand where the device is operated. Apart from the Operating Instructions, the general and local valid regulations on accident prevention and environmental protection must be provided and complied with.

Training of the Personnel

Only trained and instructed personnel is permitted to work with the device. The responsibilities of the personnel must be clearly defined for mounting, commissioning, operation, setup, maintenance, and repair. Trainees may only work with the device under the supervision of experienced personnel.

Intended Use

The device is intended exclusively to be used as a tension meter. Any other use or any use exceeding this intention will be regarded as misuse. Under no circumstances shall HANS SCHMIDT & Co GmbH be held liable for damage resulting from misuse.

The intended use also includes:

- Complying with all notices included in the Operating Instructions and observing all inspection and maintenance works.

Dangers in Handling the Device

The device was designed according to the state of the art and the approved safety standards. Nevertheless, its use may cause serious or fatal injury to the user or third persons, and/or an impairment of the device or of other material assets.

The device may only be applied:

- For its intended use in a faultless condition with regard to the safety requirements.
- Malfunctions that could impair safety must be remedied immediately.
- Personal protective equipment must be used according to the EC Directive 89/686/EEC.



The device must not be operated in potential explosive areas and must not come into contact with aggressive substances.

Copyright

The copyright on these Operating Instructions remains with the company HANS SCHMIDT & Co GmbH.

These Operating Instructions are intended for the operating company and its personnel only. They contain instructions and notices that may only be reproduced on the prior written permission of

HANS SCHMIDT & Co GmbH

and under indication of the complete reference data.

Violations will be prosecuted.

Declaration of Conformity, RoHs II and WEEE Registration

In compliance with the EU Directives 2014/30/EU and 2011/65/EU



HANS SCHMIDT & CO GmbH is registered in compliance with the German Electrical and Electronic Equipment Act (ElektroG) under WEEE Reg. No. DE 48092317.

Force Measurement with Strain Gauges

Technical Information

The strain gauge technology is the major method to measure forces. Various mechanical designs of compression or bending type sensors are being used to measure strain.

The translation of the elongation proportional to the force into a voltage signal is generally made with a full Wheatstone bridge in conjunction with appropriate amplifiers. Several sensors can be connected in parallel to obtain average values. The amplifiers are available as DIN rail mount versions or field enclosures to be mounted close to the point of measurement.

In addition to permanently mounted amplifiers a specifically designed portable analysis system is available for the continuous monitoring of force measurement values. The hand-held system PAD can e.g. capture compression forces and transmit them via an interface. The PC based portable FAS system can be used for comprehensive analyses.

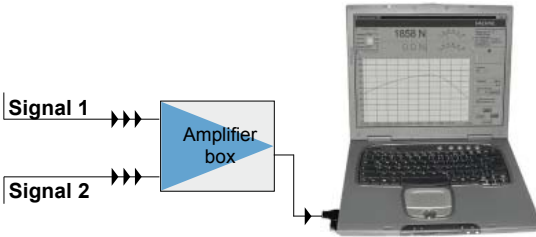

The FAS software runs on a standard PC. Additional hardware components have been designed for the continuous measurement and storage of one or two force signals.

The value of each measurement is stored together with the corresponding measurement time. Thus it is possible to perform additional analyses with such standard software as MS Excel®

Web Tension Measurement Systems

Functional Principle and Circuitry Versions

In processes where running webs of material are continuously manufactured with increasing process speeds and higher demands on quality it is necessary to measure and control the tension forces in the material. This applies equally well to the production and converting of plastic foil, textiles, paper, and metal as well as wires and cables.



Because the forces cannot be measured directly in those in running webs it is necessary to measure the forces acting on the bearings of idler rolls. The measured values are proportional to web tension if the systems are correctly dimensioned.

Because of possible non symmetrical load distribution over the rolls it is customary to measure the forces in both bearings of the idler roll. The core of the web tension sensors are strain gauge transducers measuring the acting forces.

Amplifiers, increasingly common with digital fieldbus interfaces, raise the very low sensor signals to the appropriate levels.

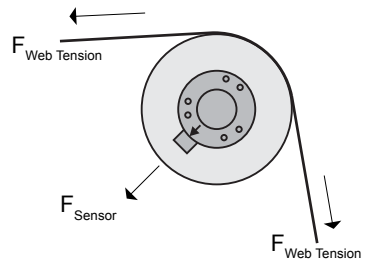

The „standard“ measuring system consists of two sensors and one amplifier. The second sensor is not necessary if the web runs steady in the middle of the rolls and the process does not require high precision web tension measurement. The analog output of the amplifier can be either voltage or current signals. Depending upon the sensor cable length the amplifiers are either housed in field enclosures mounted close to the sensors or alternatively DIN rail enclosures are available for mounting in electrical cabinets.

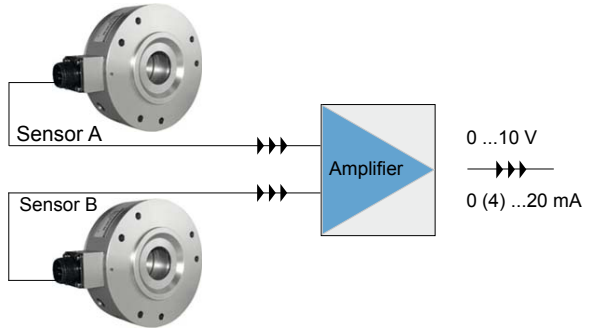

The picture shows an example of the transmission of averages.

However, when using an additional fieldbus amplifier the force values of each sensor can be used to determine e. g. the differential web tension of the system.

If fieldbus amplifiers are used, then the force values can be send directly onto the fieldbus.

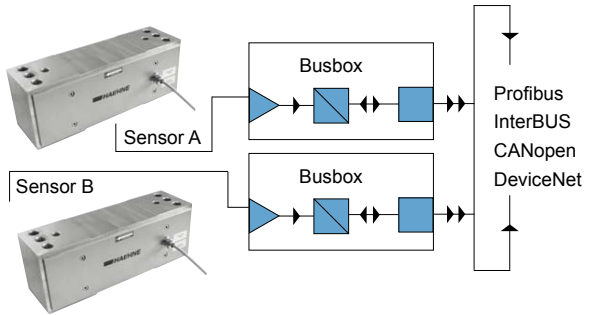

Web Tension Measurement Systems

Closed Loop Control

Constant web tension is the most frequent requirement when processing webs. For this purpose the actual value of the amplifier is compared to the set point in the controller and the difference being used to adjust drives or act directly e.g. on brakes.

The available amplifier controller combination minimizes the number of required components and reduces also circuit design and wiring effort.

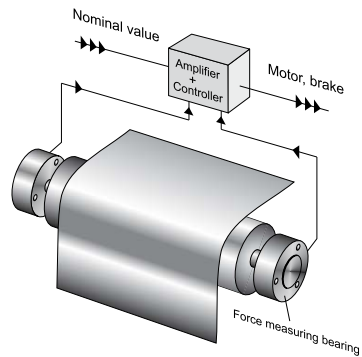

Web Tension Measurement Systems

Force Sensor Design and Areas of Application

In case of measurement at both ends of the idler roll, three basic design versions are available depending on the type of machinery and equipment environment:

Flange Design

For vertical machine frames this design offers mounting advantages. The measurement direction of the sensor can be moved to any angle in order to adjust it optimally to the web geometry and nominal force rating of the sensor. In general, however, the horizontal force measurement direction offers the advantage of eliminating the force component of the roll weight. In case of other geometries the force component of roll weight can be eliminated with the amplifier. The sensors are symmetrical and can measure tension as well as compression forces. Therefore, it is possible to use these sensors also e. g. for roll pressure measurement.



Pillow Block Design

For process lines with larger forces pillow block bearings are frequently used. The under pillow block sensors are specifically designed to fit the space between the actual pillow block bearing and the mounting frame. Horizontal mounting frames are most frequently used for pillow block bearings. There are two sensor versions available measuring either horizontal or vertical to assure the best fit for the varying web geometries .



Hub Design

The force sensor SFK and the mounting accessories flange ring and clamping block allow mounting to both horizontal and vertical machine frames. For this reason the sensor is especially well suited for single-sided narrow web and wire applications.



Measuring Idler Rolls

Complete measuring rolls are available for dual bearing support as well as single-sided bearing support e.g. for narrow web printing machines. The web tension measuring rolls MES and MWF contain integrated force sensors



Location of Web Tension Measurement

Selection Criteria

When selecting the position of web tension measurement in a machine care should be taken to use the rolls presently installed. Ensure that the wrap angle does not vary at the idler roll under consideration.

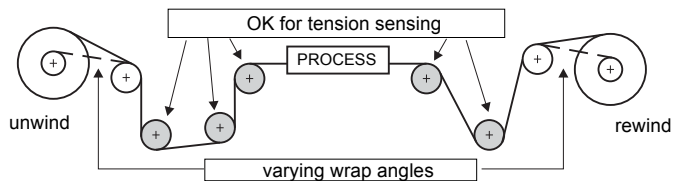

- Equipment which changes the web tension such as brakes, driven rolls, cooling and heating rolls have to be considered.
- A change of the wrap angle has an effect on the measuring results. A larger wrap angle is advantageous.
- Unfavorable environmental conditions (heat, changing temperatures, contamination, liquids) should be avoided.

Web Tension Measurement Systems

Establishment of Nominal Force Rating

The web tension sensors are generally designed for a specific measuring direction marked in most cases by a red dot. Web forces in that measuring direction generate positive force signals. If the forces do not act exactly in the measuring direction, the sensor will display a lower force according to the angles of the acting forces.

The measuring ranges follow a geometrical progression and enable a sensor selection most suitable for the actual web tension force situation. The necessary measuring range is determined by the largest expected web tension force and the web tension geometry (compare diagrams).

The machine design determines the infeed and runout web angles. This specifies also the direction of the force vectors F_1 and F_2 . For the calculation it is assumed that the measuring roll is neither driven nor braked and that the bearing friction is negligible. Under this condition the values of the vectors are equal to the maximum web tension force. Trigonometric functions and the actual mounting situation of the sensors enable the calculation of the web tension force in the measuring direction. The sum of the two parts F_{M1} and F_{M2} acts on the roll and half of the total on each sensor. In case of horizontal measurement it is not necessary to account for the roll weight, because it acts only vertically. However, in case of horizontal measurement the maximum permitted transverse force according to the product specification has to be observed.

Roll weight forces in the measuring direction can be zero adjusted at the amplifier.

Example

Web tension F = 1000 N
 Infeed angle α = 40 °
 Runout angle β = 20 °
 Measuring direction M = horizontal

Force per sensor:

$$F_M = \frac{1}{2} (F_{M1} + F_{M2})$$

$$F_M = \frac{F}{2} (\cos \alpha + \cos \beta)$$

$$= \frac{1000 \text{ N}}{2} (0,766 + 0,94) \quad \underline{\underline{F_M = 853 \text{ N}}}$$

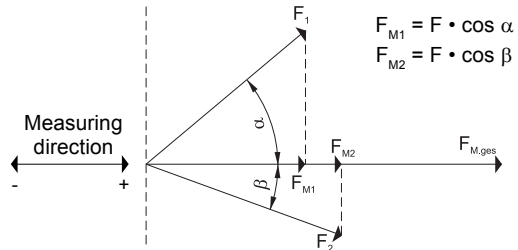

In this example 1000 N Web tension result in 853 N on each sensor. With a correctly adjusted amplifier 1000 N Web tension result in an output signal of 10 V

The force measuring systems consist of sensors and electronic modules to amplify low millivolt signals. In order to enable trouble free operation and adherence to electromagnetic interference precautions the following points have to be observed:

Electronic Modules

Mounting instructions:

1. Units that have been designed for DIN rail enclosure mounting, have to be placed in metal enclosures such as electrical cabinets.
2. The modules should be mounted away from strong noise generating sources such as power switches, frequency transformers or impedances.
3. Noise suppression measures should be used at the mounting place for such components as alternating or direct current coils, contactors, relays or varistors.
4. Electronic modules should not be mounted on top of each other in order to prevent heat accumulation.

Wiring instructions:

1. A potential equalization cable with sufficient cross section has to be provided between electrically conducting components. Electrically conducting mounting frames and DIN rails should be included in the potential equalization of the machine.
2. Use shielded cables for control and signal leads.
3. All signal inputs that are not used should be connected to a defined potential or ground earth.
4. Cable shields should be connected only single-sided and connected to the PE of the amplifier.

* In case of field enclosures the cable shield should be connected within the EMI glands to the metal enclosure.



* Electronic modules in DIN rail enclosures should be mounted in such a way that the cable shield is connected to the DIN rail via a PE terminal next to the module.

5. Cable lengths between sensors and amplifier should be kept to a minimum.
6. By connecting components of a fieldbus system use only the specified cables and connectors of the respective bus system.
7. Do not place signal cables adjacent to power cables or signals with high step rising edge. A cross over at an 90° angle is permissible.
8. In order to avoid grounding problems it is useful to connect GND and PE at a defined point within the equipment. Additional connections (e.g. internal in individual modules) can lead to functional interference.

Safety Instructions



1. If damage is visible or the unit malfunctions switch off power immediately.
2. Before opening a unit switch off the power supply.
3. Opening of the unit and making adjustments within the unit should be made only by trained personal.
4. Touching printed circuits and electronic components should be avoided because of the danger of destruction by electrostatic energy.
5. All applicable guidelines and safety instructions relating to electrical and electronic systems as well as country specific safety instructions should be observed.

Electrical Connections for Sensors

Connections and Wire Assignment

Electrical Connections

Depending on the sensor type various versions of electrical connections are offered. The corresponding variants are listed in the respective product descriptions.

The standard cable length for all options is 5 meters. Cable lengths up to 20 meters are available on request.



S1, S2, N1, N2

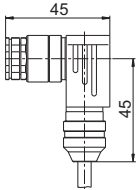

Variant S1
Plug connection
right-angled, M12, metal

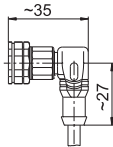

Variant S2
Plug connection
right-angled, M12, moulded

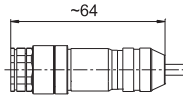

Variant N1
Plug connection,
straight, M12, metal

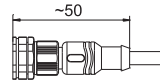

Variant N2
Plug connection
straight, M12, moulded

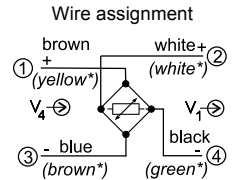

V_4 : Supply voltage
 V_1 : Signal voltage

* Alternative
color coding

S, S3, S4, N3

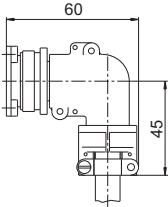

Variant S
Plug connection
right-angled, MIL

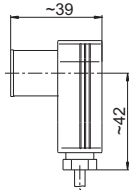

Variant S4
Plug connection
right-angled, C091

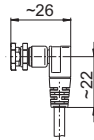

Variant S3
Plug connection
right-angled, M8,
moulded

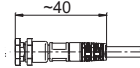

Variant N3
Plug connection
straight, M8,
moulded

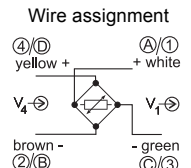

V_4 : Supply voltage
 V_1 : Signal voltage

T

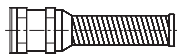
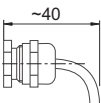

Cable gland, design dependent on sensor type.

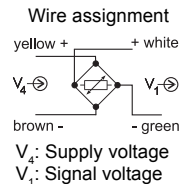

Mounting of Web Tension Sensors

Directions of Force

The sensors must be mounted according to the calculated web geometry and used only as intended. See also "Safety Instructions".

Force sensors are designed for a particular Web tension direction. Of the acting forces only the component acting in the measurement direction is analyzed.

Forces acting perpendicular to the measurement direction ($F_{Lateral} / F_{Axial}$) have to be considered and should be minimized.

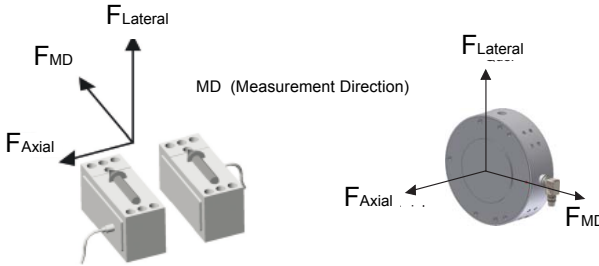

Messrichtung (F_{MD})

The measuring direction of the sensors is indicated with a red dot or marked by an arrow (See arrow in the picture). At the installation this marking must point towards the measuring direction. Mount the sensors at measuring rolls in such a way, that the arrow or red dot of both sensors point in the same direction.

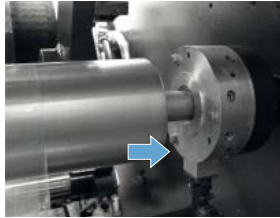

Lateral Force ($F_{Lateral}$)

A lateral force describes the force which is acting at a 90° angle relative to the measurement plane. This is caused by the roll weight or some other component of the forces acting on the sensor. The lateral force need not to be analyzed, but the value should **not exceed** the nominal force of the sensor.

Attention!

$$F_{Lateral} < F_{Nominal}$$



Attention!



Use spherical or joint bearing

Unavoidable mounting inaccuracies or roll bending results in strains in the sensor and incorrect measurement results can destroy the component. The use of spherical bearings in case of life shafts or joint bearings in case of fixed shafts can provide relief.

Mounting of Web Tension Sensors

Fixed- /Floating Bearing

Axial Force ($F_{Lateral}$)

Increasing temperature results in lateral expansion of the roll. This is compensated by applying the principle of fixed/floating bearings. The fixed bearing is absorbing the lateral and radial forces and should be placed close to the application of the operational force. The floating bearing should absorb radial forces only. The bearing must be free to move in the lateral direction, in order to allow temperatures induced expansion of the shaft. This expansion has no influence on the measurement precision.

Principle of fixed- /floating bearing as simplified sketch

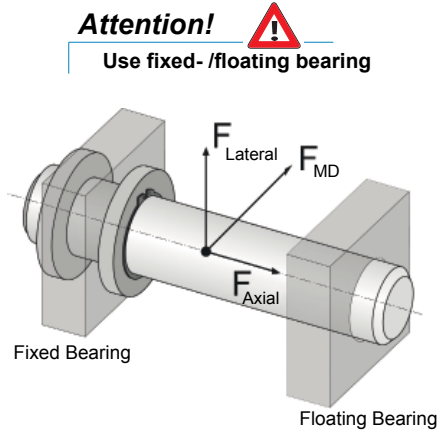

Mounting of Web Tension Sensors

Tightening Torque

The surfaces of the upper and lower mounting surface must be clean and free of foreign material. Mount the sensor only with the designated bore holes.

Pillow Block Design

Under no circumstance should the side covers be damaged. The gaskets are integrated in these covers.

Use ring bolts for safe transport (see pic.)



Screw size	Tightening Torque [Nm]
M16	210
M20	410
M30	2000

Flange Design

Shaft or axle must not affect the cover.

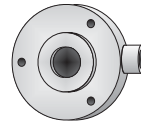

Sensor Size	Tightening Torque [Nm]	
	Fixing screws	Cover screws
1	7	hand-tight
2	7	hand-tight
3	16	5
4	32	5

Mounting Instruction Bearing Support - Flange Design

Fixed Bearing

1

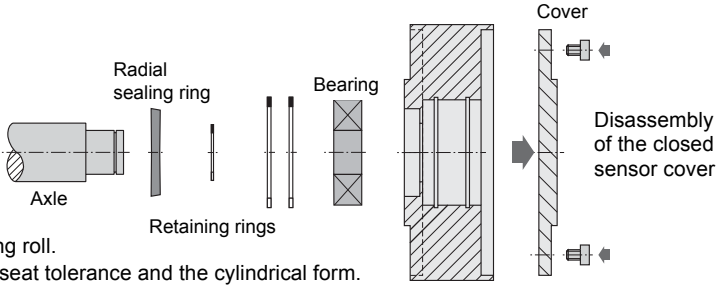

Radial sealing ring

Axle

Retaining rings

Bearing

Cover

Disassembly of the closed sensor cover

Clean the bearing seat of the measuring roll.
Inspect the bearing seat tolerance and the cylindrical form.
All components should be mounted without excessive force.
If necessary re-work.

2

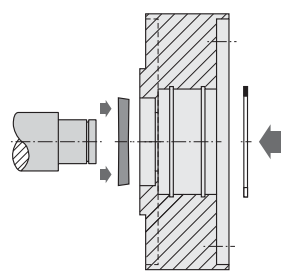

Insert radial sealing ring (optional) into the sensor cover. First insert retaining ring (DIN 472) into the inner part of sensor. Push the sensor onto the axle.

3

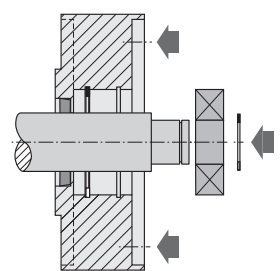

Mount the bearing on the shaft and lock with retaining ring (DIN 471) on the axle. The assembly force should act only at the inner part of the bearing. Control the axial clearance. If necessary insert a shim (DIN 988) between bearing and retaining ring.

4

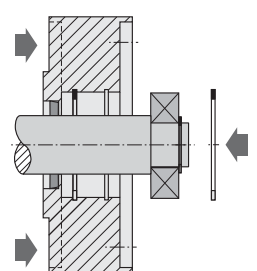

Push the sensor over the bearing and lock with second retaining ring (DIN 472)

5

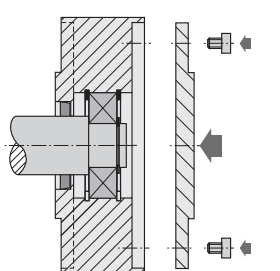

Mount closed sensor cover.
(Tightening torque see table on page 12)

Mounting Instruction Bearing Support - Flange Design

Floating Bearing

1

Clean the bearing seat of the measuring roll.
Inspect the bearing seat tolerance and the cylindrical form. All components should be mounted without excessive force. If necessary re-work.

Disassembly of the closed sensor cover

2

Insert radial sealing ring (optional) into the sensor cover. Push the sensor onto the axle.

3

Mount the bearing on the shaft and lock with retaining ring (DIN 471) on the axle. The assembly force should act only at the inner part of the bearing. Control the axial clearance. If necessary insert a shim (DIN 988) between bearing and retaining ring.

4

Push the sensor over the bearing.
Do **not** clamp the bearing in the sensor.
Mount closed sensor cover.
(Tightening torque see table on page 12)

5

The thermal expansion occur with the traverse movement of the bearing

As a rule the measuring chain does not have to be calibrated. The sensors are adjusted with a certain sensitivity and the analog amplifiers have been adjusted accordingly.

When desired we supply calibration certificates for the sensors. For the digital amplifiers the amplification is individually adjustable (DMA) or given (bus amplifiers).

If a calibration should be necessary after a regular inspection or in case of a fault *HAEHNE* recommends the following approach:

Preparation:

- For analog amplifiers: Connect a digital volt meter with sufficient accuracy and resolution to the voltage output
- Energize the device and await the operating temperature
- Take the load off the sensor
- Adjust zero point

Web Tension Calibration

Variant A - Loading with Reference Weight

- Model the web geometry with a belt or rope in the middle of the measuring roll.
Please ensure that the Web geometry in front and back of the measuring roll is identical to the operating conditions. The wrapped rolls must turn easily (e.g. not driven rolls).
- Connect one end of the rope to a fixed point. Apply a precisely determined reference weight at the other end of the roll. The weight force should be 70 to 100% of the nominal force. A calibration force closer to the nominal force leads to a more precise calibration result.
- Check the values and adjust if necessary.

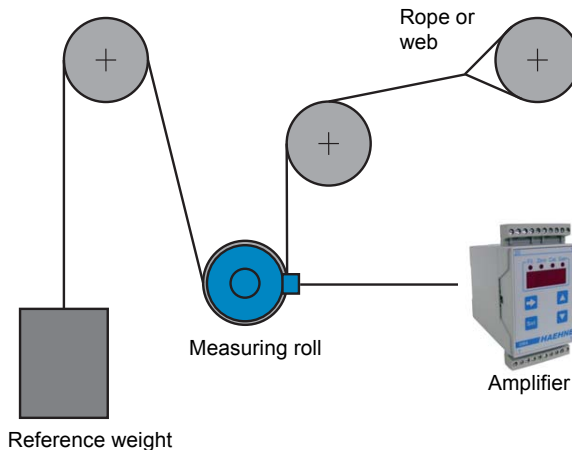

- Selection of a reference sensor with an Analysis/Display System. The accuracy of this reference sensor must be higher than the mounted web tension sensor, because **the accuracy of the reference sensor determines the total accuracy**
- Use a stroke cylinder to gradually apply at least the nominal force to the sensor
- Attach a reference sensor to the cylinder and mount both into the machine in such a way that the force direction corresponds to the measuring direction. Ensure that lateral and axial acting forces are excluded.
- Other preparations see "Calibration Variant A"

Alignment for horizontal measuring direction

Attention!



Ensure the correct measuring direction!

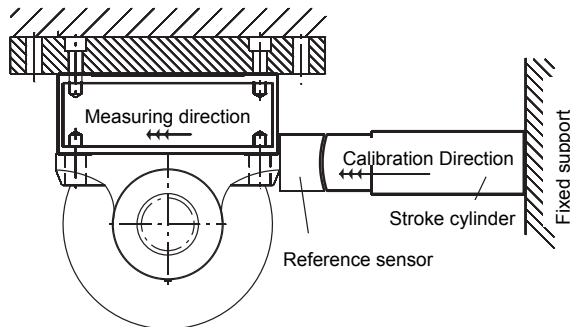

Attention!



Risk of accident!

If the measurement results do not appear plausible, then it is possible to verify the results with the same procedure that was used for the Web tension calibration. A few measuring points are sufficient for that: 0, 50, 100% of the nominal force increasing and decreasing as shown in the table below.

For the verification of the linearity, it is necessary to measure the amplifier input voltage with a high resolution digital voltmeter with a mV-scale and high input resistance. We recommend for this procedure a 10% increase or decrease of the force.

It is not so important to perform this procedure exactly in steps of 10 %. Important is the simultaneous capture of the corresponding values:

- Measured force of the reference sensor
- Output signal of the sensor in mV
- Amplifier output voltage

With such a protocol the telephone support is in a better position to help you with fault localization:

Reference Sensor	
Nominal force	
Combined error	
Manufacturer	

Web Tension Sensor	
Supply voltage (V_{4+} , V_{4-})	
Mounting area	
Serial number	

Measured Force Reference sensor [in % of nominal force]	Measured Force of Reference sensor [kN]	Output Signal of Full Bridge Strain Gauge V_{1+} , V_{1-} [mV]*	Direct Voltage Output V_{2+} , V_{2-} [V]	Display of Web Tension [kN]
0				
50				
100				
50				
0				

* Digital multi meter with resolution and input resistance as high as possible

Date:

Tester:

Maintenance

The systems do not require any maintenance under normal operating conditions. In case of overload, however, check the zero force value. The equipment should not be opened. The systems do not contain any parts that can wear out. For critical applications it is recommended to have sensors and electrical modules as spare parts on hand.

Fault Notes

Additional acting forces such as lateral, friction and torque can produce measuring errors. The occurrence of lateral forces can be avoided by following the instruction in the mounting section. Friction and torque have to be considered separately.

Web tension sensors capture the sum of the force components in the measuring direction of both the infeed and runout web portions. The exact determination of the web tension force is only possible if the measuring idler roll turns very easily creating the same force components in the infeed and runout web portions.

Possible Reasons for Measuring Errors:

- Higher friction forces by damaged roll bearings
- Friction by rotary connection or feed-through, e.g. with chill rolls
- Contact of the measuring roll with pressure rolls, strippers, or brushes
- Drives or brakes are connected to measuring roll
- Acceleration and deceleration forces acting at the measuring roll during speed changes
- Bending forces in the web when winding and unwinding
- The actual mounting position is different from the design
- Torque of mounting screws not according to specification
- Fixed and floating bearing not correctly mounted
- Liquids entered the cavities of the sensors

Declaration of Conformity, CE Designation

The *HAEHNE* Company declares, that all of their manufactured force measurement equipment are in conformity with the basic protection requirements, that are defined in the

Directive 2014/30/EC (EMI Directive)

for harmonization of laws of the Member States regarding electromagnetic compatibility in order to obtain

CE Marking

in accordance to the labeling obligation.

For the evaluation of the products regarding the electromagnetic compatibility the following harmonized standards are applied:

EMI-Emission: **EN 61000-6-4**

EMI-Immunity: **EN 61000-6-2**

Manufacturer Declaration, Machinery Directive

The *HAEHNE* Company declares, that the

Machinery Directive 2006/42/EC

do not apply to their products (Force measurement systems)

When mounting these products into machines to which the EC directive applies then it is necessary to ensure - before commissioning the machines - that the machines are built according to the standards of the EC directives 2006/42/EC.

Terms and Definitions of Characteristics

Terms	Unit	Definition
Nominal Force F_{nom})	N / kN / MN	The force for which the sensor has been designed.
Measuring Range	N / kN / MN	The force range for the intended use of the sensor. The accompanying error limits should not be exceeded within the range.
Operating Force	%	The maximum force in the measuring direction that a sensor with overload protection can be exposed to without losing its measuring properties. The operating force of sensors without overload protection equals the absolute maximum force.
Absolute Max. Force	%	The maximum permissible force for the sensor which does not damage its measuring characteristics. The specified error limits do not apply to this force.
Nominal Rating	mV/V	The nominal rating of a sensor describes the output signal of that sensor under the application of the nominal force in relation to the bridge alimentation voltage. A force sensor with a nominal rating of 1,5 mV/V with 10 V bridge alimentation voltage and an application of nominal force (100%) generates an output signal of 15 mV.
Combined Error	%	The largest single error of the sensor output is smaller than the error value of this combined error class.
Reproducibility	%	Deviation of the output signal after repeated application of the same force or after an extended period of time or variations of the applied force.
Linearity Deviation	%	Maximum deviation of the output signal from the straight line of best fit under continuously increasing force in relation to the final value of the measuring range.
Hysteresis	%	Relative difference of the measurement values between increasing and decreasing application of the load.
Nominal Ambient Temperature	°C	The temperature range in which the sensor functions within the limits of specified technical data and the error limits.
Operational Temperature Range	°C	The temperature range in which the sensor functions without permanent damage to the measurement properties. The specific error limits do not apply, however, to this temperature range.
Nominal Resistance of Strain Gauge	Ω	The ohmic resistance of the total full bridge is used to determine the load of the supply voltage resulting from the force sensor.
Supply Voltage	V DC	Alimentation voltage of the force sensor to ensure error and fault free operation. The highest value specified for the force sensor should not be exceeded to avoid excessive increase in temperature of the strain gauge.
Enclosure Protection Ratings	IP	1 st number: 2 = protect against objects greater than 12 mm 5 = dust protected 6 = dust tight; 2 nd number: 0 = not protected, 4 = protection against splashing water, 5 = against water jets, 6 = against powerful water jets, 7 = against effects of immersion, 8 = against submersion.

Correspondence

Should you have any questions regarding the instrument or Operating Instructions, or their use, please indicate above all the following details which are given on the ID plate:

- 1) Model
- 2) Serial number

Repairs

Shipping instructions:

We kindly ask for return free of charge for us, if possible by airmail parcel. All occurring charges, if any (such as freight, customs clearance, duty etc.), will be billed to customer. For return from foreign countries, we ask you to include a proforma invoice with a low value for customs clearance only, e.g. 50 Euro, each and to advise the shipment in advance by fax or eMail.

 **To avoid unnecessary follow-up questions, and the resulting loss of time or possible misunderstandings, please return the instrument with a detailed fault description to our service department. Please indicate in your order whether you require an Inspection Certificate 3.1 according to DIN EN 10204.**

Service address:

**HANS SCHMIDT & Co GmbH
Schichtstr. 16
D-84478 Waldkraiburg
Germany**

Notes:

SCHMIDT

control instruments

SCHMIDT-Test-Instruments
indispensable in production monitoring,
quality control and automation
We solve your measuring problems:



Tension Meter



Force Gauge



Torque Meter



Tachometer



Speed- and Lengthmeter



Electronic Lengthmeter



Stroboscope



Screen Printing Tension Meter



Thickness Gauge



Yarn Package Durometer and Shore Durometer



Sample Cutter



Balance



Moisture Meter



Leak Tester

More than 75 years - Worldwide -

Hans Schmidt & Co GmbH

Mailing address:

P. O. B. 1154
84464 Waldkraiburg Germany

Shipping address:

Schichtstr. 16
84478 Waldkraiburg Germany

Phone:

int. + 49 / (0)8638 / 9410-0

Fax:

int. + 49 / (0)8638 / 4825

int. + 49 / (0)8638 / 67898

e-mail:

info@hans-schmidt.com

Internet:

http://www.hans-schmidt.com