

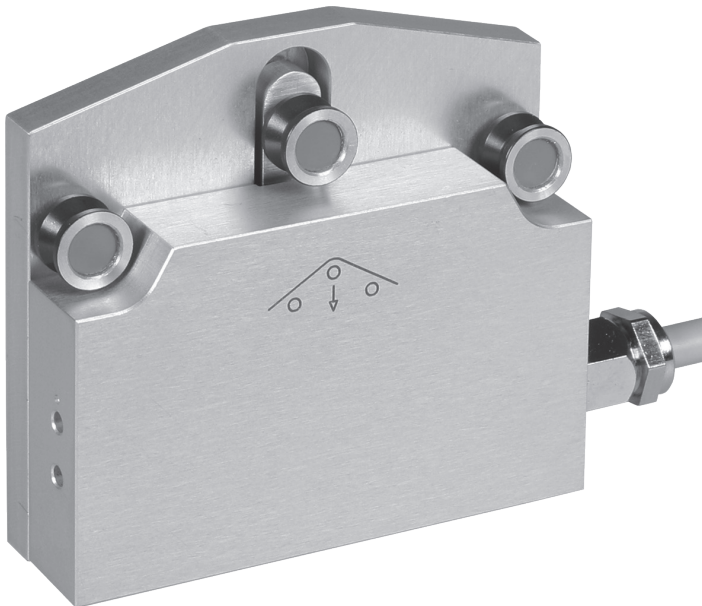

Instruction Manual

Valid as of: 15.08.2014 • Please keep the manual for future reference!



Contents

1 Warranty and liability	3
1.1 Notices within the instruction manual	3
1.2 Responsibilities of the operating company	3
1.3 Responsibilities of the personnel	3
1.4 Informal safety measures	4
1.5 Training of the personnel	4
1.6 Intended use	4
1.7 Dangers in handling the device	4
1.8 Copyright	4
1.9 Declaration of conformity, RoHs II and WEEE registration	4
2 Available models	5
2.1 General information	5
2.1.1 Available MAZF, MBZF models	5
2.1.2 Available MAZD, MBZD models	6
2.1.3 Available MBZB models	6
2.2 Specifications of the MZ series	6
2.3 Assignment of the connector	7
2.3.1 Connecting the tension meter	7
2.4 Optional accessories	7
2.5 Delivery includes	7
2.6 Unpacking	7
3 Operating procedure	8
3.1 Initial setup	8
3.1.1 Setup MAZF and MAZD	8
3.1.2 Setup MBZF, MBZD and MBZB	9
3.2 Internal adjustment of the sensors	9
3.2.1 Zero adjustment	10
3.2.2 Gain adjustment	11
4 Service and maintenance	12
4.1 Rollers	12
5 Cleaning	12
6 Verification interval	12
6.1 Verification of calibration and determination of repair costs	13
7 Correspondence	14
8 Repairs	14

1 Warranty and liability

In principle, the supply of the device is subject to our “General Conditions of Sale and Delivery.” These have been provided to the operating company on conclusion of the contract, at the latest.

Warranty:

- SCHMIDT tension meters are warranted for 12 months.
- Parts subject to wear, electronic components and measuring springs are not covered by the warranty. No warranty or liability will be accepted for bodily injury or property damage resulting from one or several of the following causes:
- Misuse or abuse of the device.
- Improper mounting, commissioning, operation and maintenance of the device (e.g. verification interval).
- Operation of the device if any safeguards are defective or if any safety and protection precautions are not properly installed or not operative.
- Failure to comply with the notices in the instruction manual regarding transport, storage, mounting, commissioning, operation, maintenance and setup of the device.
- Any unauthorized structural alteration of the device.
- Insufficient inspection of device components that are subject to wear.
- Opening the device or improper repair work.
- Disasters caused by the effects of foreign objects or by force majeure.

1.1 Notices within the instruction manual

The fundamental prerequisite for the safe handling of this device and its troublefree operation is the knowledge of the basic safety notices and safety instructions.

These instruction manual contain the most important notices for the safe operation of the device.

These instruction manual, in particular the safety notices, must be observed by any person who works with the device. In addition, the local valid rules and regulations for the prevention of accidents must be complied with.

The representations within the instruction manual are not true to scale.

The dimensions given are not binding.

General indications of direction, such as FRONT, REAR, RIGHT, LEFT apply when viewing the front of the device.

1.2 Responsibilities of the operating company

In compliance with the EC Directive 89/655/EEC, the operating company agrees to only permit persons to work with the device who:

- are familiar with the basic regulations on industrial safety and accident prevention and who have been trained in handling the device.
- have read and understood the chapter on safety and the warning notices in these instruction manual and have confirmed this with their signatures.
- are examined regularly on their safe and conscientious working method.

1.3 Responsibilities of the personnel

All persons who work with the device agree to perform the following duties before starting work:

- to observe the basic regulations on industrial safety and accident prevention.
- to read the chapter on safety and the warning notices in these instruction manual and to confirm with their signatures that they have understood them.

1.4 Informal safety measures

The instruction manual must always be kept on hand where the device is operated. Apart from the instruction manual, the general and local valid regulations on accident prevention and environmental protection must be provided and complied with.

1.5 Training of the personnel

Only trained and instructed personnel is permitted to work with the device. The responsibilities of the personnel must be clearly defined for mounting, commissioning, operation, setup, maintenance, and repair. Trainees may only work with the device under the supervision of experienced personnel.

1.6 Intended use

The device is intended exclusively to be used as a tension meter. Any other use or any use exceeding this intention will be regarded as misuse. Under no circumstances shall Hans Schmidt & Co GmbH be held liable for damage resulting from misuse.

The intended use also includes:

- Complying with all notices included in the instruction manual and observing all inspection and maintenance works.

1.7 Dangers in handling the device

The device was designed according to the state of the art and the approved safety standards. Nevertheless, its use may cause serious or fatal injury to the user or third persons, and/or an impairment of the device or of other material assets.

The device may only be applied:

- For its intended use in a faultless condition with regard to the safety requirements.
- Malfunctions that could impair safety must be remedied immediately.
- Personal protective equipment must be used according to the EC Directive 89/686/EEC.



The device must not be operated in potential explosive areas and must not come into contact with aggressive substances.

1.8 Copyright

The copyright on these instruction manual remains with the company Hans Schmidt & Co GmbH.

These instruction manual is intended for the operating company and its personnel only. They contain instructions and notices that may only be reproduced on the prior written permission of

Hans Schmidt & Co GmbH

and under indication of the complete reference data.

Violations will be prosecuted.

1.9 Declaration of conformity, RoHs II and WEEE registration

In compliance with the EU Directives 2014/130/EU and 2011/65/EU



Hans Schmidt & Co GmbH is registered in compliance with the German Electrical and Electronic Equipment Act (ElektroG) under WEEE Reg. No. DE 48092317.

2 Available models

2.1 General information

These instruction manual refer to the MAZF model of the MZ series; they are also applicable to the following models:

MBZF, MAZD, MBZD, MBZB

The individual models of the MZ series are also available with the following modifications (customized versions):

- Customized roller dimensions and materials
- Special calibration using customer supplied material

The instruction manual can also be used for these instruments as their handling is the same.

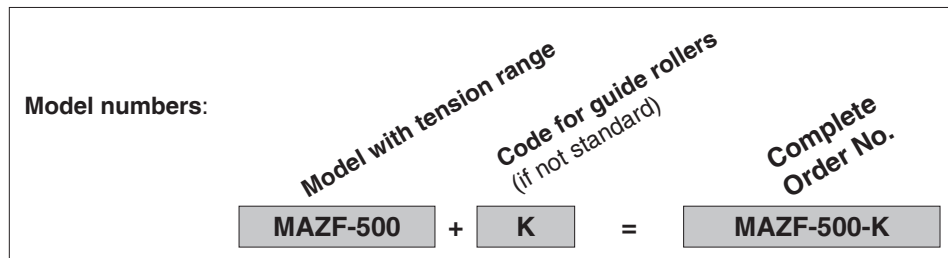

2.1.1 Available MAZF, MBZF models

Model	Model	Tension Range [cN]	*Measuring Head Width [mm]	**Schmidt Calibration Material
MAZF-100	MBZF-100	0 - 100	70	PA: 0.12 mm Ø
MAZF-200	MBZF-200	0 - 200	70	PA: 0.12 mm Ø
MAZF-500	MBZF-500	0 - 500	70	PA: 0.20 mm Ø



* Outside dimensions of the housing.

** Suitable for 95% of applications. PA = Polyamide Monofilament
 International unit of tensile force: 1 cN = 1.02 g = 0.01 N

MAZF, MBZF guide rollers:

V-Groove	Line Speed [m/min ... max.]	Roller Material
Standard	900	Hard-coated aluminium
Code K	2000	Hard-coated aluminium

2.1.2 Available MAZD, MBZD models

Model	Model	Tension Range [cN]	*Measuring Head Width [mm]	**Schmidt Calibration Material
MAZD-200	MBZD-200	0 - 200	70	PA: 0.20 mm Ø
MAZD-500	MBZD-500	0 - 500	70	PA: 0.20 mm Ø
MAZD-1000	MBZD-1000	0 - 1000	70	PA: 0.30 mm Ø



* Outside dimensions of the housing.

** Suitable for 95% of applications. PA = Polyamide Monofilament

International unit of tensile force: 1 cN = 1.02 g = 0.01 N

MAZD, MBZD guide rollers:

V-Groove	Line Speed [m/min ... max.]	Roller Material
Standard	2000	Hard-coated aluminium
Code K	3500	Hard-coated aluminium
Code H	5000	Plasma-coated aluminium
Code CE2	1000	Ceramic-coated aluminium

2.1.3 Available MBZB models

Model	*Tension Range [cN]	**Measuring Head Width [mm]	Roller Widths [mm]
MBZB-200	0 - 200	70	7, 10
MBZB-500	0 - 500	70	7, 10
MBZB-1000	0 - 1000	70	7, 10



* SCHMIDT calibration with a textile ribbon or film according to tension range and roller width.

** Outside dimensions of the housing.

MBZB guide rollers:

V-Groove	Line Speed [m/min ... max.]	Roller Material
Standard	1000	Hard-coated aluminium

2.2 Specifications of the MZ series

Calibration:

According to SCHMIDT factory procedure

Accuracy:

± 2 % full scale and 1 ± 1 digit

Other calibration material: ± 3 % full scale or better

Overload protection:

100 % of range

Measuring principle:

Strain gauge bridge

Meas. roller deflection:

0.5 mm, max.

Natural frequency of measuring spring:

Approx. 500 Hz, depending on tension range

Signal processing:

Analog

Output signal:

0 - 1 V DC, impedance: ≥ 5 kOhm (standard)

Option Code **A2**:

0 - 10 V DC

Option Code **A10**

Analog DMS output 0.6 mV/V without amplifier

2.2 Specifications of the MZ series

Damping (f_g):	Standard: approx. 30 Hz (other values on request)
Temperature coefficient:	Zero point: less than ± 0.05 % full scale/ $^{\circ}\text{C}$
Temperature range:	10 - 45 $^{\circ}\text{C}$
Air humidity:	85 % RH, max.
Power supply:	15 ... 24 V DC, 21 mA (regulated) Code A10: max. 5 V DC, max. 20 mA (regulated)
Housing:	Aluminium
Dimensions:	70 x 63 x 17 mm (L x W x H)
Weight, net (gross):	With cable approx. 210 g (300 g)

2.3 Assignment of the connector

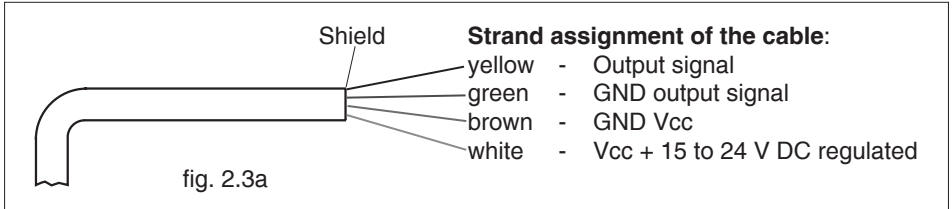

Assignment of the cable for sensors with output signal Code A10 (max. cable length 15 m)

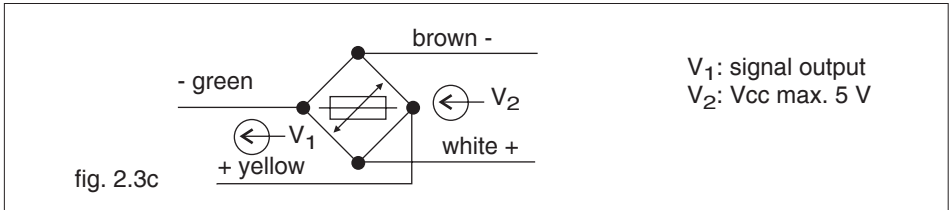

2.3.1 Connecting the tension meter



The requirements of the CE specification are only complied with if the tension sensor is equipped and operated with display units and connecting cables supplied by Hans Schmidt & Co GmbH. Certification to the CE specification does not extend to, and shall be invalid for any other combination. Under no circumstances shall Hans Schmidt & Co GmbH be held liable for any damage resulting from the use of non-SCHMIDT sensors or cables.

2.4 Optional accessories

- Code **A2**: Analog output 0 - 10 V DC
- Code **A10**: Analog DMS output 0.6 mV/V without amplifier

2.5 Delivery includes

- Sensor
- Instruction manual

2.6 Unpacking

Unpack the instrument and inspect it for any shipping damage. Notices of defect must be announced immediately, in writing, at the latest within 7 days on receipt of the goods.

3 Operating procedure



Tensions that exceed the tension range of the instrument by more than 100% may cause permanent damage to the measuring spring and must be avoided under any circumstances.

In no event shall Hans Schmidt & Co GmbH take over any warranty coverage for, or shall be held liable for, any damage resulting from self-made cables.



The model number, the serial number, the calibration label (option) and the SCHMIDT Quality Seal are provided on the rear side of the sensor.

3.1 Initial setup

3.1.1 Setup MAZF and MAZD

- Install the sensor at the desired measuring location. The sensor can be mounted with the three boreholes (M3-10 mm depth), which are located on the bottom side of the unit (fig 3.1a) or can be snapped in at a mounting rail with the optional available adapter (fig 3.1b), that is mounted ex works at the sensor.

The material incoming and outgoing angle must be 35° (fig. 3.1c)

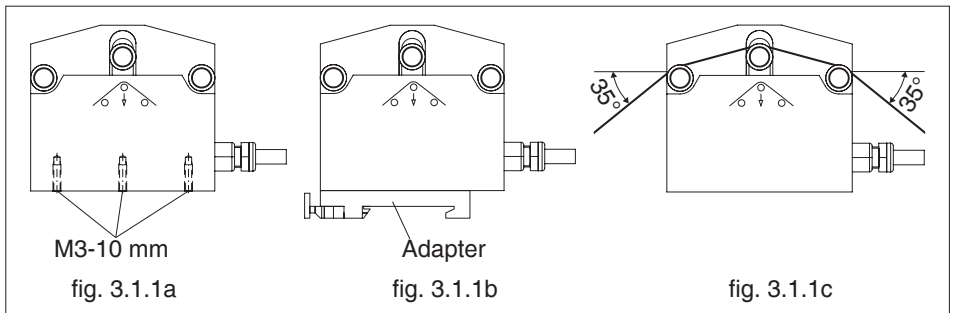

- Connect the sensor to the supplied or existing display unit.
- If the material path is other than vertical or if the process material deviates significantly from the SCHMIDT calibration material, you need to carry out zero adjustment and gain adjustment as described in chapters 3.2.1 and 3.2.2 before starting measurement.
- Allow approx. 10 minutes for thermal stabilization of the sensor.
- Thread the process material through the measuring and guide rollers, following the material path symbol on the front of the sensor.



The process material must be thread in corresponding to the material path symbol, otherwise the load cell can be damaged.
The material incoming and outgoing angle must be 35° to get accurate readings. The angle must not be under 35° to avoid material slip. If the angle is more than 35° the reading differs from the actual tension

3.1.2 Setup MBZF, MBZD and MBZB

- Install the sensor at the desired measuring location. The sensor can be mounted with the three boreholes (M3-10 mm depth), which are located on the bottom side of the unit (fig 3.1a) or can be snapped in at a mounting rail with the optional available adapter (fig 3.1b), that is mounted ex works at the sensor.

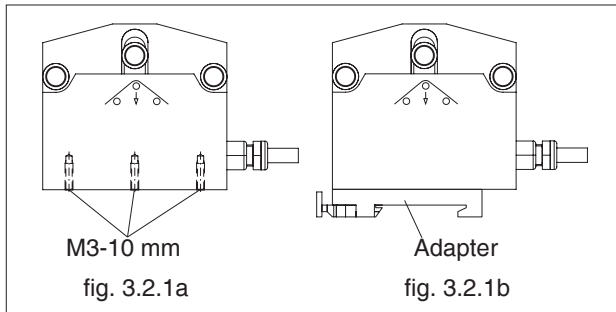

- Connect the sensor to the supplied or existing display unit.
- If the material path is other than vertical or if the process material deviates significantly from the SCHMIDT calibration material, you need to carry out zero adjustment and gain adjustment as described in chapters 3.2.1 and 3.2.2 before starting measurement.
- Allow approx. 10 minutes for thermal stabilization of the sensor.
- Thread the process material through the measuring and guide rollers, following the material path symbol on the front of the sensor.



The process material must be thread in corresponding to the material path symbol, otherwise the load cell can be damaged.

3.2 Internal adjustment of the sensors

General information:

If the sensor has been delivered with a display unit, the zero and gain adjustments should only be carried out with the supplied display unit.

All tension meters are calibrated with standard materials - such as polyamide monofilament (PA) - according to the SCHMIDT factory procedure; the material path is vertical. Any difference in process material size and rigidity from the standard material may cause a deviation of the accuracy.

In 95% of all industrial applications the SCHMIDT calibration has been proven to provide the best results and is used for comparative purposes.

If required you can also operate the sensors with a material path other than vertical.

Should the process material differ significantly from the SCHMIDT calibration material in size, rigidity or shape, we recommend special calibration using customer supplied material. If the material path is other than vertical or if the process material deviates significantly from the SCHMIDT calibration material, you need to carry out static **zero** and **gain adjustment** as described in chapters 3.2.1 and 3.2.2.

3.2.1 Zero adjustment

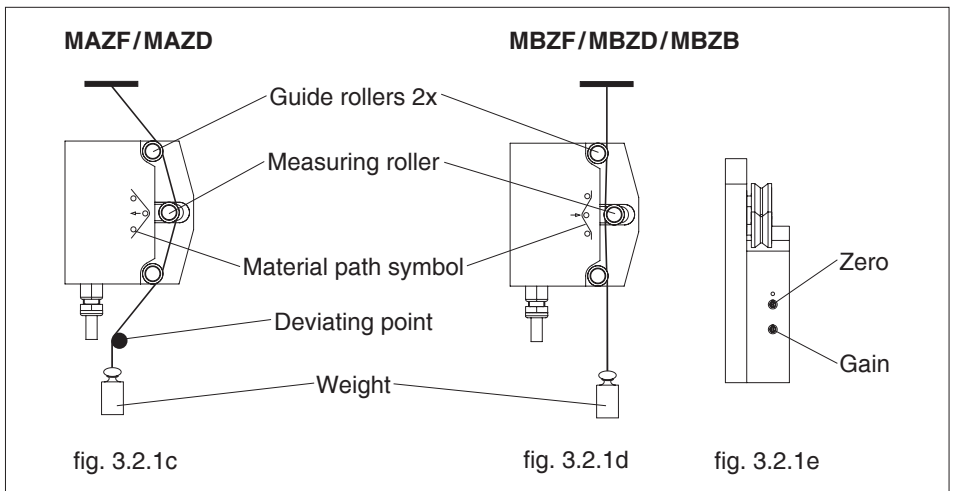
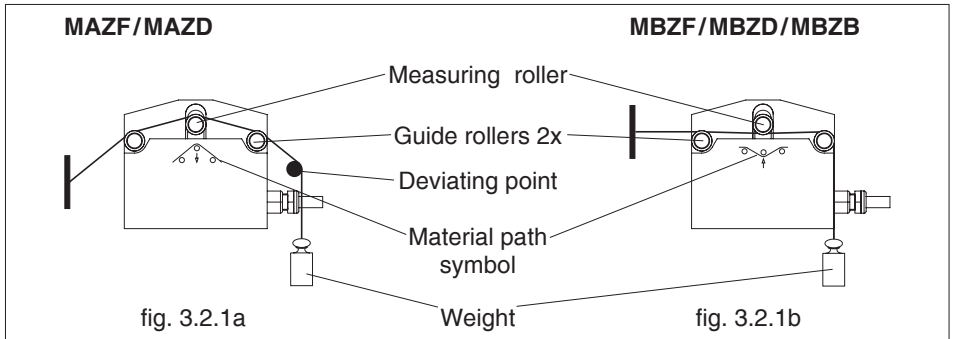

- Install the sensor in the desired position at the measuring location (chapter 3.1).
- Allow approx. 10 minutes for thermal stabilization of the sensor.
- Thread the process material through the measuring and guide rollers, following the material path symbol on the front of the sensor.



When threading the process material through the rollers, follow the material path symbol on the front of the sensor. If a force is applied to the middle sensor roller in the incorrect direction, damage could result.

To get the needed incoming and outgoing angle of 35° with the models MAZD and MAZF, a deviating point must be mounted at the test preparation.



Since zero and gain adjustments are always performed statically, the readings may differ under dynamic load.

3.2.1 Zero adjustment (cont.)

- Hang on a weight that corresponds to e.g. 10% of the tension range from the process material.
- Connect a volt meter to the yellow and green lead of the connecting cable.
- Adjust the potentiometer, which you can reach through the ZERO hole in the housing, with a screwdriver (with a point width of max. 1.9 mm) until the display of the connected volt meter reads,
for example:
Sensor model MAZF - 200:
Weight 20 cN = Display 0.100 V for the MAZF standard version
or
Weight 20 cN = Display 1.00 V for the MAZF version with 10 V output signal.



Do not insert the screwdriver at an angle as this may damage the potentiometer.
Zero adjustment of sensors with output signal Code A10 has to be realized with display unit SC-PM

3.2.2 Gain adjustment

Requirement: Zero adjustment carried out.

- Thread the process material through the measuring and guide rollers, following the material path symbol on the front of the sensor.
- Hang a weight that corresponds to e.g. 100 % of the tension range from the process material.
 - Adjust the potentiometer, which you can reach through the gain hole in the housing, with a screwdriver (with a point width of max. 1.9 mm) until the display of the connected volt meter reads,
for example:
Sensor model MAZF - 200:
Weight 200 cN = Display 1.000 V for MAZF standard version
or
Weight 200 cN = Display 10.00 V for MAZF version with 10 V output signal.
 - Check the adjustments by using a new filament of the process material and repeat the procedure, if required, as described in chapters 3.2.1 and 3.2.2.



Do not insert the screwdriver at an angle as this may damage the potentiometer.
Gain adjustment of sensors with output signal Code A10 has to be realized with display unit SC-PM

4 Service and maintenance

The tension meter is easy to maintain. Depending on operating time and load, the instrument should be checked according to the locally valid regulations and conditions (as described in chapter 3.3). The use of other test methods than the procedure described in chapter 3.3 may cause deviating measuring results.

4.1 Rollers

You should regularly inspect the rollers to assure that they are running easily and smoothly. You can replace the rollers yourself, as necessary. Please indicate the tension meter model and the serial number in your spare-parts order.

5 Cleaning

For cleaning the unit, do not use any



AGGRESSIVE SOLVENTS

such as trichloroethylene or similar chemicals.



NO WARRANTY OR LIABILITY

shall be accepted for damage resulting from improper cleaning.

6 Verification interval

The question of finding the right frequency of calibration accuracy verification depends on several different factors:

- ➔ Operating time and load of the SCHMIDT tension meter
- ➔ Tolerance band defined by the customer
- ➔ Changes to the tolerance band compared to previous calibrations

Therefore, the interval between verifications of calibration must be determined by the user's Quality Assurance Department, based on the user's experience.

Assuming normal operating time and load as well as careful handling of the tension meter, we recommend a verification interval of one year.

6.1 Verification of calibration and determination of repair costs

Flow chart for verifying the calibration of used tension meters, incoming and outgoing verification with Inspection Certificate 3.1 according to DIN EN 10204

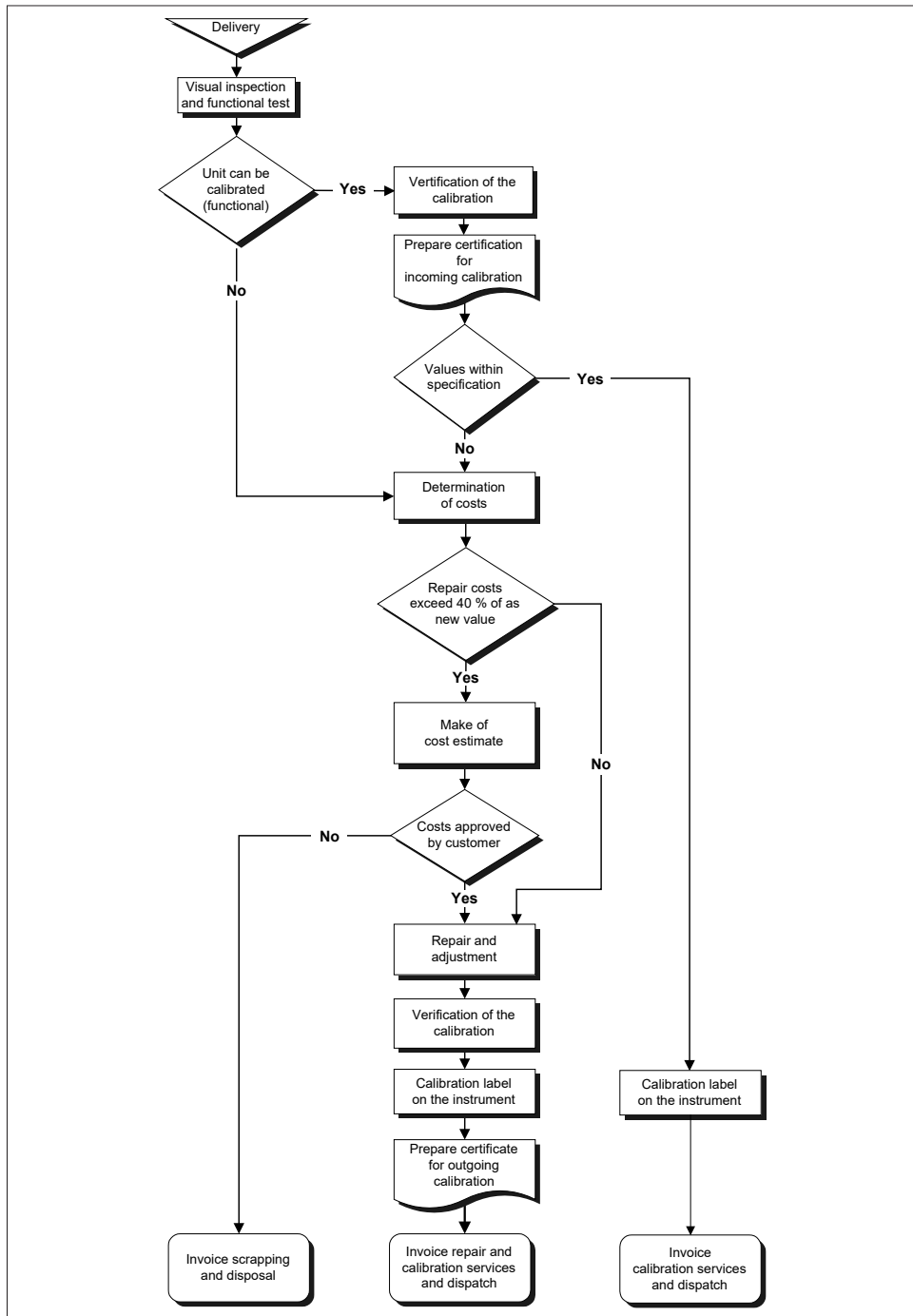

7 Correspondence

Should you have any questions regarding the instrument or instruction manual, or their use, please indicate above all the following details which are given on the ID plate:

- 1) Model
- 2) Serial number

8 Repairs

Shipping instructions:

We kindly ask for return free of charge for us, if possible by airmail parcel. All occurring charges, if any (such as freight, customs clearance, duty etc.), will be billed to customer. For return from foreign countries, we ask you to include a proforma invoice with a low value for customs clearance only, e.g. 50 Euro, each and to advise the shipment in advance by fax or eMail.

1 To avoid unnecessary follow-up questions, and the resulting loss of time or possible misunderstandings, please return the instrument with a detailed fault description to our service department. Please indicate in your order whether you require an Inspection Certificate 3.1 according to DIN EN 10204.

Service address:

**Hans Schmidt & Co GmbH
Schichtstr. 16
84478 Waldkraiburg
Germany**

Subject to change without notice!

Notes:

SCHMIDT

control instruments

SCHMIDT-Test-Instruments
indispensable in production monitoring,
quality control and automation
We solve your measuring problems:



Tension Meter



Force Gauge



Torque Meter



Tachometer



Speed- and Lengthmeter



Electronic Lengthmeter



Stroboscope



Screen Printing Tension Meter



Thickness Gauge



Yarn Package Durometer and Shore Durometer



Sample Cutter



Balance



Moisture Meter



Leak Tester

More than 75 years - Worldwide -

Hans Schmidt & Co GmbH

Mailing address:

P. O. B. 1154
84464 Waldkraiburg Germany

Shipping address:

Schichtstr. 16
84478 Waldkraiburg Germany

Phone:

int. + 49 / (0)8638 / 9410-0

Fax:

int. + 49 / (0)8638 / 4825

int. + 49 / (0)8638 / 67898

e-mail:

info@hans-schmidt.com

Internet:

http://www.hans-schmidt.com