

Durometer

SCHMIDT
control instruments



Edition: HPSA-R 03.3.E

HPSA-R Series

Model HPSA-R20-M
HPSA-R35-M
HPSA-R55-M

Instruction Manual

Valid as of: 01.01.2010 • Please keep the manual for future reference!

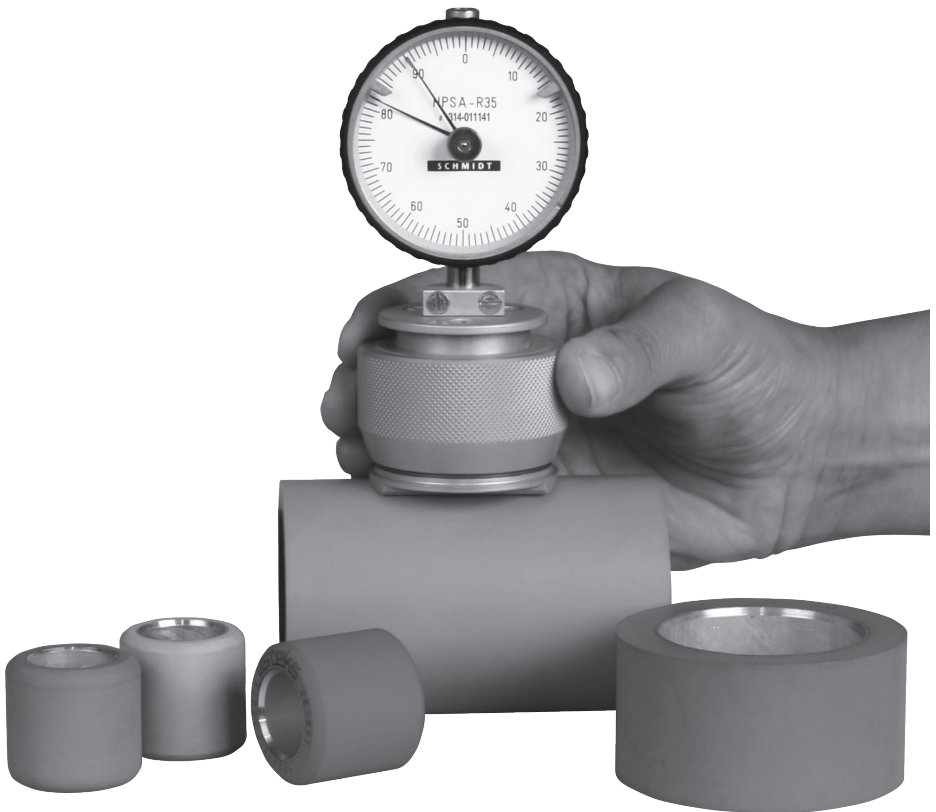

SCHMIDT · ALL OVER THE TECHNICAL WORLD

Contents

1 Warranty and liability	3
1.1 Notices within the instruction manual	3
1.2 Responsibilities of the operating company	3
1.3 Responsibilities of the personnel	3
1.4 Informal safety measures	4
1.5 Training of the personnel	4
1.6 Intended use	4
1.7 Dangers in handling the device	4
1.8 Copyright	4
1.9 Declaration of conformity	4
2 Available models	5
2.1 Specifications	6
2.2 Delivery Includes	6
2.3 Unpacking	6
3 Operating procedure	6
3.1 Notices before starting measurement	6
3.2 Measuring with the durometer	6
3.3 Verification of calibration	8
4 Optional accessories	9
5 Service and maintenance	10
6 Cleaning	10
7 Verification intervals	10
8 Correspondence	10
9 Repairs	10

1 Warranty and liability

In principle, the supply of the device is subject to our “General Conditions of Sale and Delivery.” These have been provided to the operating company on conclusion of the contract, at the latest.

Warranty:

- SCHMIDT durometers are warranted for 12 months.

Parts subject to wear, electronic components and measuring springs are not covered by the warranty. No warranty or liability will be accepted for bodily injury or property damage resulting from one or several of the following causes:

- Misuse or abuse of the device.
- Improper mounting, commissioning, operation and maintenance of the device (e.g. verification interval).
- Operation of the device if any safeguards are defective or if any safety and protection precautions are not properly installed or not operative.
- Failure to comply with the notices in the instruction manual regarding transport, storage, mounting, commissioning, operation, maintenance and setup of the device.
- Any unauthorized structural alteration of the device.
- Insufficient inspection of device components that are subject to wear.
- Opening the device or improper repair work.
- Disasters caused by the effects of foreign objects or by force majeure.

1.1 Notices within the instruction manual

The fundamental prerequisite for the safe handling of this device and its troublefree operation is the knowledge of the basic safety notices and safety instructions.

This instruction manual contains the most important notices for the safe operation of the device.

These instruction manual, in particular the safety notices, must be observed by any person who works with the device. In addition, the local valid rules and regulations for the prevention of accidents must be complied with.

The representations within the instruction manual are not true to scale.

The dimensions given are not binding.

General indications of direction, such as FRONT, REAR, RIGHT, LEFT apply when viewing the front of the device.

1.2 Responsibilities of the operating company

In compliance with the EC Directive 89/655/EEC, the operating company agrees to only permit persons to work with the device who:

- are familiar with the basic regulations on industrial safety and accident prevention and who have been trained in handling the device.
- have read and understood the chapter on safety and the warning notices in these instruction manual and have confirmed this with their signatures.
- are examined regularly on their safe and conscientious working method.

1.3 Responsibilities of the personnel

All persons who work with the device agree to perform the following duties before starting work:

- to observe the basic regulations on industrial safety and accident prevention.
- to read the chapter on safety and the warning notices in these instruction manual and to confirm with their signatures that they have understood them.

1.4 Informal safety measures

The instruction manual must always be kept on hand where the device is operated. Apart from the instruction manual, the general and local valid regulations on accident prevention and environmental protection must be provided and complied with.

1.5 Training of the personnel

Only trained and instructed personnel is permitted to work with the device. The responsibilities of the personnel must be clearly defined for mounting, commissioning, operation, setup, maintenance and repair. Trainees may only work with the device under the supervision of an experienced personnel

1.6 Intended use

The device is intended exclusively to be used as durometer. Any other use or any use exceeding this intention will be regarded as misuse. Under no circumstances shall Hans Schmidt & Co GmbH be held liable for damage resulting from misuse.

The intended use also includes:

- Complying with all notices included in the instruction manual and observing all inspection and maintenance works.

1.7 Dangers in handling the device

The device was designed according to the state of the art and the approved safety standards. Nevertheless, its use may cause serious or fatal injury to the user or third persons, and/or an impairment of the device or of other material assets.

The device may only be applied:

- For its intended use in a faultless condition with regard to the safety requirements.
- Malfunctions that could impair safety must be remedied immediately.
- Personal protective equipment must be used according to the EC Directive 89/686/EEC.



The device must not be operated in potentially explosive areas and must not come into contact with aggressive substances.

1.8 Copyright

The copyright on these instruction manual remains with the company Hans Schmidt & Co GmbH.

These instruction manual is intended for the operating company and its personnel only. They contain instructions and notices that may only be reproduced on the prior written permission of

Hans Schmidt & Co GmbH

and under indication of the complete reference data.

Violations will be prosecuted.

1.9 Declaration of conformity

Our mechanical durometers do not belong to the EC machinery directive 2006/42/EC and do not have a CE mark.

2 Available models

General information on Shore hardness testing:

The principle used to measure hardness is based on measuring the resistance force of the penetration of a sensing pin of defined geometry into the test material under a known spring load. The amount of penetration is measured and indicated on a scale with 100 Shore graduation marks. The hardness scale covers a range from 0 to 100, where 0 corresponds to the minimum and 100 to the maximum hardness value. As the amount of penetration of the sensing pin is 2.5 mm max., the material to be tested should have a minimum thickness of 6 mm. The proper Shore hardness of rubber-coated rollers, in particular of cots, has a decisive influence on quality. As the cots are subject to wear, and as rubber ages, the Shore hardness must be measured and verified regularly.

Overview of the application limits of the individual Shore hardness test procedures

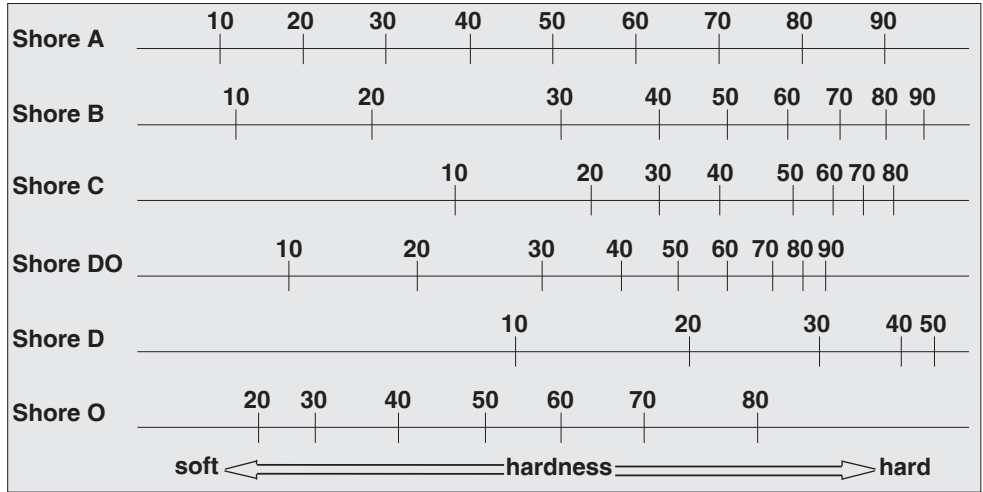

Model	Shore	Typical Applications
HPSA-R20-M	A	For roller diameters up to 40 mm Ø
HPSA-R35-M	A	For roller diameters from 40 mm Ø to 70 mm Ø
HPSA-R55-M	A	For roller diameters from 70 mm Ø to 110 mm Ø

With uniform test pressure system

Following DIN 53505, ISO 48-4, ISO 868, ASTM D 2240

2.1 Specifications

	HPSA-R20-M	HPSA-R35-M	HPSA-R55-M
Shore hardness:	A**		
Recommended roller Ø:	< 40 mm	40 - 70 mm	70 - 110 mm
Working face radius:	20 mm	35 mm	55 mm
Indenter:	Truncated Cone 35°  1.25 mm Ø		
Application range:	10 - 90 Shore A units		
Display range:	0 - 100 Shore A units		
Depth of indentation:	0 - 2.5 mm		
Test pressure*:	Approx. 12.5 N		
Measuring spring force:	0.55 - 8.065 N		
Scale diameter:	51 mm		
Housing diameter:	44.5 mm Ø		
Weight net (gross):	Approx. 300 g (500 g)		
Dimensions (L x W x H):	50 x 60 x 110 mm		

* Pressure on test material surface when outer shell is in measuring position (colored line)

** Following DIN 53505, ISO 48-4, ISO 868, ASTM D 2240

2.2 Delivery Includes

- Durometer
- Operating manual
- Certificate of Compliance with the order 2.1 according EN 10204
- Carrying case

2.3 Unpacking

Unpack the instrument and inspect it for any shipping damage.

Notices of defect must be announced immediately, at the latest within 7 days on receipt of the goods.

3 Operating procedure

3.1 Notices before starting measurement



Have you read and understood the instruction manual, in particular chapter 1 „Warranty and liability“ ?

You are not permitted to operate the instrument before doing so.

Before working with the instrument you must put on your personal protective clothing, if necessary. For example, eye protectors, gloves, etc.

3.2 Measuring with the durometer

General information

The material to be tested must comply to the applicable standard. Use of other material will lead to incorrect measurement results.

Example for Shore A hardness:

The material to be tested must be thicker than 6 mm. When testing thinner material, you may need to place several samples on top of each other until a thickness of 6 mm is reached.

Each test sample has to be tested in at least three different points. The points should be > 5 mm apart and > 13 mm away from the sample edges.

3.2 Measuring with the durometer (cont.)

The hardness reading must be recorded 3 seconds after pressing down the knurled outer shell. When testing material with a significant tendency to yield, the value can be read after 15 seconds. The duration of the measurement must be indicated in the test report. The instrument is equipped with a memory pointer which moves with the scale pointer when a measurement is taken. However, when pressure on the outer shell is released, and the scale pointer returns to zero, the memory pointer remains in position, marking the highest reading (Peak) of the measurement. The durometer additionally has two movable markers that can be rotated around the faceplate to mark any desired measuring range within the display range.

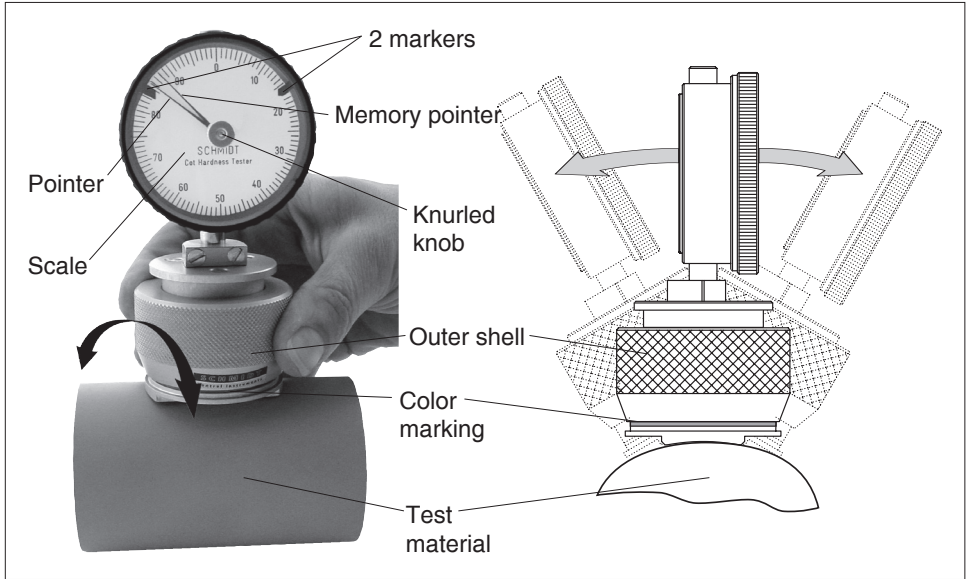

Requirements

- Rotate the knurled knob to reset the memory pointer to the zero position.

Measurement procedure

- Place the instrument on the material to be tested. The durometer must be level, and the sensing pin must be perpendicular to the material to be tested. Any angle other than perpendicular may cause error.
- Holding the knurled, spring-loaded outer shell between fingers, press downwards until the lower edge of the shell meets the red line marked on the housing. This ensures that the same amount of pressure is applied from measurement to measurement and prevents measuring errors. Rock the unit back and forth two to three times on the surface of the material to be tested to ensure a correct measuring result.
- Record the reading of the memory pointer. The hardness scale covers a range from 0 to 100, where 0 corresponds to the minimum and 100 to the maximum hardness value. Each test sample has to be tested in at least three different points.

3.3 Verification of calibration

The Shore durometer is calibrated against industry standards as specified in ASTM and DIN Test Procedures. Calibrated test samples CAN NOT BE USED for verification of the calibration as these test samples are subject to change due to temperature, sunlight and other ambient conditions.

You can, however, test that the instrument is functional and undamaged. If your instrument has a concave-shaped base, use the optional Zero Test Block for this purpose. The Zero Test Block can be ordered under the following item numbers:

Order number: HP-PR - for HPSA-R20

Order number: HP-PT - for HPSA-R35 and HPSA-R55

When you fully press down the instrument, the scale pointer should make one full turn on the scale, from zero to zero. The scale pointer should return to the initial zero position when you release pressure. If it does not, return the instrument to the manufacturer for servicing.

Optional calibration certification must be ordered separately, prior to delivery of the instrument. Subsequent calibration is only possible at the manufacturer's facilities.

To verify calibration of durometer models: HPSA-R20, HPSA-R35 and HPSA-R55

- Press the durometer down on the Zero Test Block (fig. 3.3).

Do not move the spring-loaded outer shell.

The scale pointer should make one full turn on the scale, from zero to zero.



Do not loosen the holding screws of the movement under any circumstances. Loosening these screws may alter the calibration of the instrument.

Model HPSA-R20, HPSA-R35, HPSA-R55

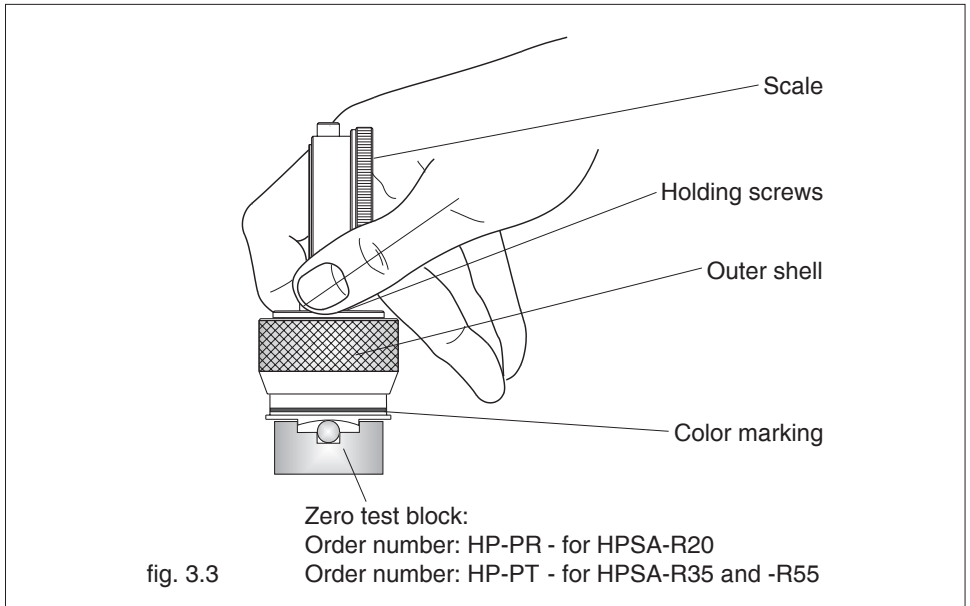

4 Optional accessories

Test Stand

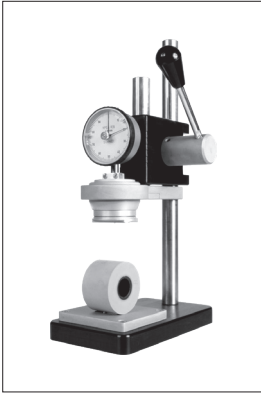

Test Stand

Model PSHP for serial testing

- Spring-loaded lever for easy use
- Height adjustable from 0 to 200 mm
- Travel of operating lever: 40 mm
- Dimensions LxWxH: 162 x 100 x 320 mm
- Net weight: approx. 2.3 kg

Base plate and prisms optionally available, please ask for further details.

Test Block for checking displacement



Model HP-PR

for hardness tester HPSA-20R

Model HP-PT

for hardness tester HPSA-35R and HPSA-55R

5 Service and maintenance

The tension meter is easy to maintain. Depending on operating time and load, the tension meter should be checked according to the locally valid regulations and conditions (as described in Chapter 3.3). The use of other test methods than the procedure described in Chapter 3.3 may cause deviating measuring results.

6 Cleaning

For cleaning the unit, do not use any



AGGRESSIVE SOLVENTS

such as trichloroethylene or similar chemicals.



NO WARRANTY OR LIABILITY

shall be accepted for damage resulting from improper cleaning.

7 Verification intervals

The question of finding the right frequency of calibration accuracy verification depends on several different factors:

- ➔ Operating time and load of the SCHMIDT hardness tester
- ➔ Tolerance band defined by the customer
- ➔ Changes of the tolerance band compared to previous verifications of calibration

Therefore, the interval between verifications must be determined by the user's Quality Assurance Department based on the user's experience.

Assuming normal operating time and load as well as careful handling of the hardness tester, we recommend a verification interval of 1 year.

8 Correspondence

Should you have any questions regarding the tension meter or instruction manual, or their use, please indicate above all the following details which are given on the ID plate:

- 1) The tension meter model
- 2) The serial number

9 Repairs

Shipping instructions:

We kindly ask for return free of charge for us, if possible by airmail parcel. All occurring charges, if any (such as freight, customs clearance, duty, etc.) will be billed to customer. For return from foreign countries, we ask you to include a proforma invoice with a low value for customs clearance only, e.g. 50 Euro, each and to advise the shipment in advance by fax or eMail.



To avoid unnecessary follow-up questions, and the resulting loss of time or possible misunderstandings, please return the tension meter with a detailed fault description to our service department. Please indicate in your order whether you require an calibration certificate with calibration report.

**Service address: Hans Schmidt & Co GmbH
Schichtstr. 16
D-84478 Waldkraiburg
Germany**

Notes:

SCHMIDT

control instruments

SCHMIDT-Test-Instruments
indispensable in production monitoring,
quality control and automation
We solve your measuring problems:



Tension Meter



Force Gauge



Torque Meter



Tachometer



Speed- and Lengthmeter



Electronic Lengthmeter



Stroboscope



Screen Printing Tension Meter



Thickness Gauge



Yarn Package Durometer and Shore Durometer



Sample Cutter



Balance



Moisture Meter



Leak Tester

More than 75 years - Worldwide -

Hans Schmidt & Co GmbH

Mailing address:

P. O. B. 1154
84464 Waldkraiburg Germany

Shipping address:

Schichtstr. 16
84478 Waldkraiburg Germany

Phone:

int. + 49 / (0)8638 / 9410-0

Fax:

int. + 49 / (0)8638 / 4825

int. + 49 / (0)8638 / 67898

e-mail:

info@hans-schmidt.com

Internet:

http://www.hans-schmidt.com