

FS Series
Option: RS-232
USB

Model FS1
FSP
FSH
FSW
FSL
FSB1

Instruction Manual

Valid as of: 01.12.2017 • Please keep the manual for future reference!

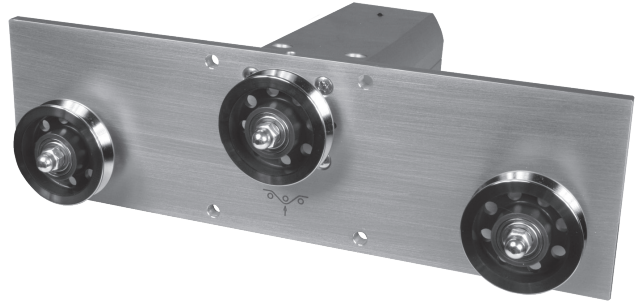
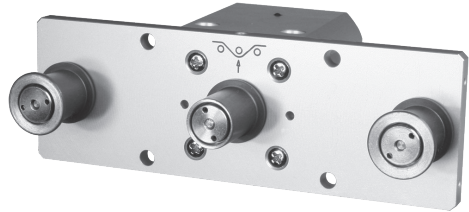

Contents

1 Warranty and liability	3
1.1 Notices within the instruction manual	3
1.2 Responsibilities of the operating company	3
1.3 Responsibilities of the personnel	3
1.4 Informal safety measures	4
1.5 Training of the personnel	4
1.6 Intended use	4
1.7 Dangers in handling the device	4
1.8 Copyright	4
1.9 Declaration of conformity, RoHs II and WEEE registration	4
2 Available models	5
2.1 General	5
2.1.1 Available FS1 models	5
2.1.2 Available FSP models	6
2.1.3 Available FSH models	7
2.1.4 Available FSW models	8
2.1.5 Available FSL models	8
2.1.6 Available FSB1 models	9
2.2 Specifications of the FS-232 and FS-USB series	9
2.3 Pin assignment of the connector (only Code 232)	10
2.4 Optional accessories	10
2.5 Delivery includes	10
2.6 Unpacking	10
3 Initial setup and operating procedure	11
3.1 Notes before starting measurement	11
3.2 Mounting possibilities	11
3.3 Connecting the sensors to a PC	12
3.4 Internal adjustment of the sensors	13
3.4.1 Zero adjustment	13
3.4.2 Gain adjustment	14
4 The »Tension Inspect 3« program	15
4.1 System requirements	15
4.2 Installing »Tension Inspect 3«	15
4.3 Using installing »Tension Inspect 3«	16
4.3.1 Basic settings	17
4.3.2 Start and stop the tension value display	18
4.3.3 Hi/Lo set-points	18
4.3.4 Graph adjustments	19
4.3.5 Print and data transfer	19
4.3.6 Save and load the readings	20
4.3.7 Online recording	20
5 PC communication	21
5.1 Windows terminal program	21
6 Service and maintenance	21
6.1 Verification of calibration and determination of repair costs	22
7 Cleaning	23
8 Correspondence	23
9 Repairs	23

1 Warranty and liability

In principle, the supply of the device is subject to our “General Conditions of Sale and Delivery.” These have been provided to the operating company on conclusion of the contract, at the latest.

Warranty:

- SCHMIDT tension meters are warranted for 12 months.

Parts subject to wear, electronic components and measuring springs are not covered by the warranty. No warranty or liability will be accepted for bodily injury or property damage resulting from one or several of the following causes:

- Misuse or abuse of the device.
- Improper mounting, commissioning, operation and maintenance of the device (e.g. verification interval).
- Operation of the device if any safeguards are defective or if any safety and protection precautions are not properly installed or not operative.
- Failure to comply with the notices in the instruction manual regarding transport, storage, mounting, commissioning, operation, maintenance and setup of the device.
- Any unauthorized structural alteration of the device.
- Insufficient inspection of device components that are subject to wear.
- Opening the device or improper repair work.
- Disasters caused by the effects of foreign objects or by force majeure.

1.1 Notices within the instruction manual

The fundamental prerequisite for the safe handling of this device and its troublefree operation is the knowledge of the basic safety notices and safety instructions.

This instruction manual contains the most important notices for the safe operation of the device.

This instruction manual, in particular the safety notices, must be observed by any person who works with the device. In addition, the local valid rules and regulations for the prevention of accidents must be complied with.

The representations within the instruction manual are not true to scale.

The dimensions given are not binding.

General indications of direction, such as FRONT, REAR, RIGHT, LEFT apply when viewing the front of the device.

1.2 Responsibilities of the operating company

In compliance with the EC Directive 89/655/EEC, the operating company agrees to only permit persons to work with the device who:

- are familiar with the basic regulations on industrial safety and accident prevention and who have been trained in handling the device.
- have read and understood the chapter on safety and the warning notices in these instruction manual and have confirmed this with their signatures.
- are examined regularly on their safe and conscientious working method.

1.3 Responsibilities of the personnel

All persons who work with the device agree to perform the following duties before starting work:

- to observe the basic regulations on industrial safety and accident prevention.
- to read the chapter on safety and the warning notices in these instruction manual and to confirm with their signatures that they have understood them.

1.4 Informal safety measures

The instruction manual must always be kept on hand where the device is operated. Apart from the instruction manual, the general and local valid regulations on accident prevention and environmental protection must be provided and complied with.

1.5 Training of the personnel

Only trained and instructed personnel is permitted to work with the device. The responsibilities of the personnel must be clearly defined for mounting, commissioning, operation, setup, maintenance and repair. Trainees may only work with the device under the supervision of an experienced personnel

1.6 Intended use

The device is intended exclusively to be used as a tension meter. Any other use or any use exceeding this intention will be regarded as misuse. Under no circumstances shall Hans Schmidt & Co GmbH be held liable for damage resulting from misuse.

The intended use also includes:

- Complying with all notices included in the instruction manual and observing all inspection and maintenance works.

1.7 Dangers in handling the device

The device was designed according to the state of the art and the approved safety standards. Nevertheless, its use may cause serious or fatal injury to the user or third persons, and/or an impairment of the device or of other material assets.

The device may only be applied:

- For its intended use in a faultless condition with regard to the safety requirements.
- Malfunctions that could impair safety must be remedied immediately.
- Personal protective equipment must be used according to the EC Directive 89/686/EEC.



The device must not be operated in potential explosive areas and must not come into contact with aggressive substances.

1.8 Copyright

The copyright on these instruction manual remains with the company Hans Schmidt & Co GmbH.

These instruction manual is intended for the operating company and its personnel only. They contain instructions and notices that may only be reproduced on the prior written permission of Hans Schmidt & Co GmbH and under indication of the complete reference data. Violations will be prosecuted.

1.9 Declaration of conformity, RoHs II and WEEE registration

In compliance with the EU Directives 2014/30/EU and 2011/65/EU



Hans Schmidt & Co GmbH is registered in compliance with the German Electrical and Electronic Equipment Act (ElektroG) under WEEE Reg. No. DE 48092317.

2 Available models

2.1 General

These instruction manual refer to the FS1 Model with digital output signal RS-232 and USB of the FS series;

they are also applicable to the following models:

FSP, FSH, FSL, FSW, FSB1

The individual models of the FS series are also available with the following modifications (customized versions):

- Customized measuring head width
- Special tension ranges
- Customized roller dimensions and materials
- Customized distance between outside guide rollers
- Special calibration using customer supplied material

The instruction manual can also be used for these instruments as their handling is the same.

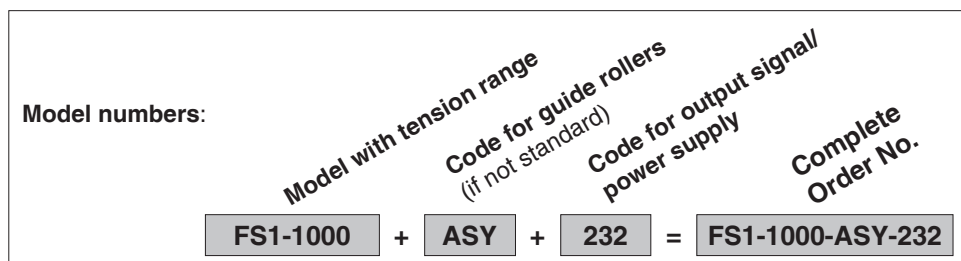

2.1.1 Available FS1 models

with RS-232 or USB interface (Code 232/USB)

Model with Tension Range	Tension Range [cN]	*Measuring Head Width [mm]	**Schmidt Calibration Material
FS1-100-	0 - 100	64	PA: 0.12 mm Ø
FS1-200-	0 - 200	64	PA: 0.12 mm Ø
FS1-500-	0 - 500	64	PA: 0.20 mm Ø
FS1-1000-	0 - 1000	64	PA: 0.30 mm Ø
FS1-2000-	0 - 2000	124	PA: 0.50 mm Ø
FS1-5000-	0 - 5000	124	PA: 0.80 mm Ø
FS1-10K-	0 - 10 daN	124	PA: 1.00 mm Ø
FS1-20K-	0 - 20 daN	224	PA: 1.50 mm Ø
FS1-50K-	0 - 50 daN	224	Steel rope: 1.5mm Ø (7 x 7 x 0.20)



* Outside dimensions of front plate.

** Suitable for 95% of applications. PA = Polyamide Monofilament
 Should the process material differ significant from the SCHMIDT calibration material in size, rigidity or shape, we recommend special calibration using customer supplied material.

International unit of tensile force: 1 cN = 1.02 g = 0.01 N

1 daN = 1.02 kg = 10.00 N

2.1.1 Available FS1 models

FS1 guide rollers:

V-Groove	Line Speed [m/min ... max.]	Roller Material
Standard	2000	Hard-coated aluminium
Code K	3500	Hard-coated aluminium
Code H	5000	Plasma-coated aluminium (FS1-100 and higher ranges)
Code ST	1000	Hardened steel
Code B	1000	Heat-treated steel, specially for measuring tire cord
Code CE2	1000	Aluminium ceramic-coated
Asymmetrical Groove Code ASY	1000	Hard-coated aluminium (FS1-500 and higher ranges)
Code ASYB	1000	Heat-treated steel (FS1-500 and higher ranges)
U-Groove Code U	2000	Hard-coated aluminium (FS1-500 and higher ranges)

2.1.2 Available FSP models

with RS-232 or USB interface (Code 232/USB)

Model with Tension Range	Tension Range [cN]	*Measuring Head Width [mm]	**Schmidt Calibration Material
FSP-100-	0 - 100	64	PA: 0.12 mm Ø
FSP-200-	0 - 200	64	PA: 0.12 mm Ø
FSP-500-	0 - 500	64	PA: 0.20 mm Ø
FSP-1000-	0 - 1000	64	PA: 0.30 mm Ø



* Outside dimensions of front plate.

** Suitable for 95% of applications. PA = Polyamide Monofilament

Should the process material differ significant from the SCHMIDT calibration material in size, rigidity or shape, we recommend special calibration using customer supplied material.

International unit of tensile force: 1 cN = 1.02 g = 0.01 N

1 daN = 1.02 kg = 10.00 N

FSP guide pins:

Ceramic Pins	Line Speed [m/min ... max.]	Pin Material
Standard	2000	Oxide ceramic 5.2 mm Ø

2.1.3 Available FSH models

with RS-232 or USB interface (Code 232/USB)

Model with Tension Range	Tension Range [cN]	*Measuring Head Width [mm]	**Schmidt Calibration Material
FSH-1000-	0 - 1000	150	PA: 0.30 mm Ø
FSH-2000-	0 - 2000	150	PA: 0.50 mm Ø
FSH-5000-	0 - 5000	150	PA: 0.80 mm Ø
FSH-10K-	0 - 10 daN	200	PA: 1.00 mm Ø
FSH-20K-	0 - 20 daN	240	PA: 1.50 mm Ø
FSH-50K-	0 - 50 daN	240	Steel rope: 1.5mm Ø (7 x 7 x 0.20)



* Outside dimensions of front plate.

** Suitable for 95% of applications. PA = Polyamide Monofilament

Should the process material differ significant from the SCHMIDT calibration material in size, rigidity or shape, we recommend special calibration using customer supplied material.

International unit of tensile force: 1 cN = 1.02 g = 0.01 N

1 daN = 1.02 kg = 10.00 N

FSH guide rollers:

V-Groove	Line Speed [m/min ... max.]	Roller Material
Standard	4000	Stainless steel 1.4125 (max. 4 mm Ø)
U-Groove Code R1	4000	Hard chrome plated steel (3 - 9 mm Ø)
Code R4	1000	Hardened steel (8 - 11 mm Ø) Model FSH-50K and higher
Code R5	1000	Hardened steel (12 - 15 mm Ø) Model FSH-50K and higher
Tape Roller Code B6	2000	Hardened steel, width 6 mm
Code B10	2000	Hardened steel, width 10 mm

2.1.4 Available FSW models

with RS-232 or USB interface (Code 232/USB)



Model with Tension Range	Tension Range [daN]	*Measuring Head Width [mm]	Schmidt Calibration Material
FSW-20K-	0 - 20	550	Steel rope: 1.5 mm Ø (7 x 7 x 0.25)
FSW-50K-	0 - 50	550	Steel rope: 3 mm Ø (6 x 7 x 0.30)
FSW-100K-	0 - 100	550	Steel rope: 4 mm Ø (6 x 7 x 0.50)
FSW-200K-	0 - 200	550	Steel rope: 4 mm Ø (6 x 7 x 0.50)

* Outside dimensions of front plate.

International unit of tensile force: 1 cN = 1.02 g = 0.01 N

1 daN = 1.02 kg = 10.00 N

FSW guide rollers:

V-Groove	Line Speed [m/min ... max.]	Roller Material
Standard	2000	Hard-coated aluminium max. wire diameter 5 mm
U-Groove Code R2	2000	Hard-coated aluminium (radius R 5)
Code R3	2000	Hard-coated aluminium (radius R8)

2.1.5 Available FSL models

with RS-232 or USB interface (Code 232/USB)



Model with Tension Range	Tension Range [cN]	*Measuring Head Width [mm]	**Schmidt Calibration Material
FSL-100-	0 - 100	150	PA: 0.12 mm Ø
FSL-200-	0 - 200	150	PA: 0.12 mm Ø
FSL-500-	0 - 500	150	PA: 0.20 mm Ø
FSL-1000-	0 - 1000	150	PA: 0.30 mm Ø

* Outside dimensions of front plate.

** Suitable for 95% of applications. PA = Polyamide Monofilament

Should the process material differ significant from the SCHMIDT calibration material in size, rigidity or shape, we recommend special calibration using customer supplied material.

International unit of tensile force: 1 cN = 1.02 g = 0.01 N

1 daN = 1.02 kg = 10.00 N

FSL guide rollers:

V-Groove	Line Speed [m/min ... max.]	Roller Material
Standard	4000	Hardcoated aluminium
Code T	4000	Plastic (PVC red) (same dimensions as standard roller)

2.1.6 Available FSB1 models

with RS-232 or USB interface (Code 232/USB)

Model with Tension Range	*Tension Range [cN]	**Measuring Head Width [mm]	Roller Widths [mm]
FSB1-100-	0 - 100	60	7, 10, 15, 20
FSB1-200-	0 - 200	60	7, 10, 15, 20
FSB1-500-	0 - 500	60	7, 10, 15, 20
FSB1-1000-	0 - 1000	60	7, 10, 15, 20, 30
FSB1-2000-	0 - 2000	120	7, 10, 15, 20, 30
FSB1-5000-	0 - 5000	120	7, 10, 15, 20, 30
FSB1-10K-	0 - 10K	120	7, 10, 15, 20
FSB1-20K-	0 - 20K	120	7, 10, 15, 20



* SCHMIDT calibration with a textile ribbon or film according to tension range and roller width.

** Outside dimensions of front plate.

FSB1 guide rollers:

V-Groove	Line Speed [m/min ... max.]	Roller Material
Standard	1000	Hard-coated aluminium

2.2 Specifications of the FS-232 and FS-USB series

Calibration:	According to SCHMIDT factory procedure
Accuracy:	± 1.5 % full scale and ± 1 digit Other calibration material: ± 3% full scale or better
Overload protection:	100% of range
Measuring principle:	Strain gauge bridge
Meas. roller deflection:	0.5 mm, max.
Natural frequency of measuring spring:	Approx. 500 Hz, depending on tension range
Signal processing:	Digital, 24 bit A/D converter, sample time max. 5000/sec Internal averaging up to 1 sec
Communication frequency:	Approx. 100 readings/sec
Output signal:	Code 232: 57600 Baud, 8 bit, none Parity, 1 stopbit, ASCII communication, 200 readings/sec Code USB: 152000 Baud, 8 bit, none Parity, 1 stopbit, ASCII communication, 500 readings/sec
Temperature coefficient:	Zero point: less than ± 0.05% full scale/°C
Temperature range:	10 - 45 °C
Air humidity:	85% RH, max.
Power supply:	Code 232: 15 to 24 V DC, 40 mA (regulated) Code USB: no external power supply is required
Housing:	Aluminium

2.3 Pin assignment of the connector (only Code 232)

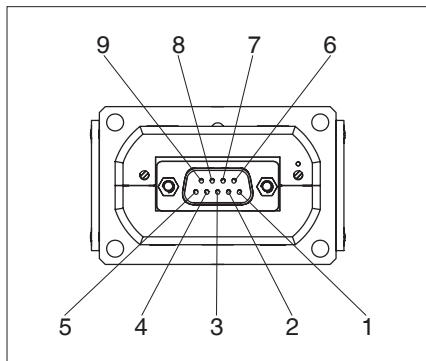

Pin No.	Signal	Description
1		Not assigned
2		Not assigned
3	GND	Ground
4	GND	Ground
5	Vcc	Vcc
6		Not assigned
7	TXD	Transmitted data
8	RXD	Received data
9	GND	Ground - RS-232

- 1** To assure immunity to random noise, the measuring head must be installed in such a way that it is insulated from ground (GND).
The shield of the connecting cable must be connected to the metal housing of the connecting plug.

2.4 Optional accessories

SW-TI3: »Tension Inspect 3« software for PC evaluation of readings

EK0640: Cable for connection to PC (only Code 232)

EK0643: Extension cable for RS-232 connecting cable EK0640 (only Code 232)

2.5 Delivery includes

- Sensor
- USB cable (only Code USB)
- Instruction manual

2.6 Unpacking

Unpack the tension meter and inspect it for any shipping damage. Notices of defect must be announced immediately, in writing, at the latest within 7 days on receipt of the goods.

3 Initial setup and operating procedure

3.1 Notes before starting measurement



Tensions that exceed the tension range of the instrument by more than 100% may cause permanent damage to the measuring spring and must be avoided under any circumstances.

Hans Schmidt & Co GmbH provides no warranty or liability for self-made cables.



The model number, the serial number, the calibration label (option) and the SCHMIDT Quality Seal are provided on the cylindrical portion of the sensor.

3.2 Mounting possibilities

Sensors of FS series can be mounted in different ways:

- Mounting by using the frontplate on a cylindrical hole (panel cut out R 19 mm, Length 54 mm)
- Mounting on a flat platform

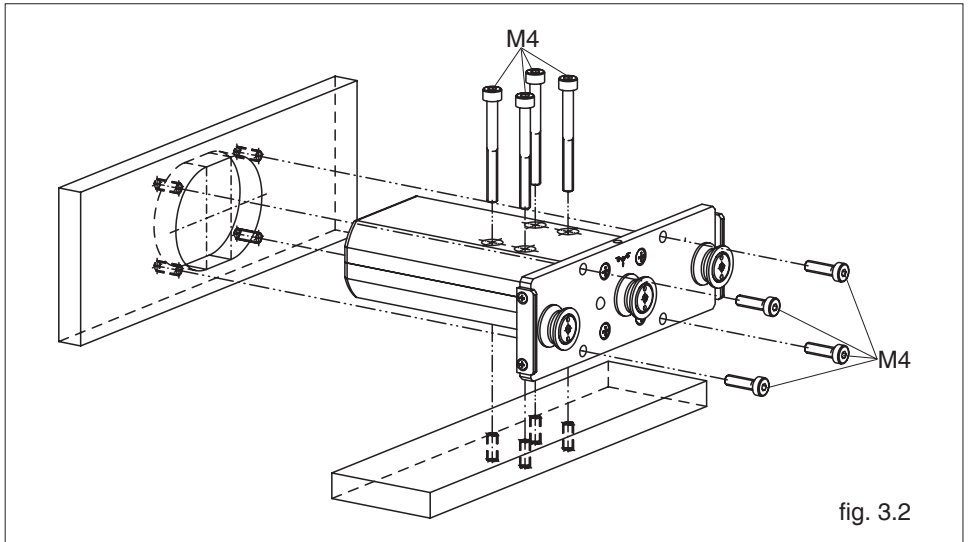

The LED on the front of the sensor flashes lightly, if the sensor is connected accurate.

3.3 Connecting the sensors to a PC

Code RS-232

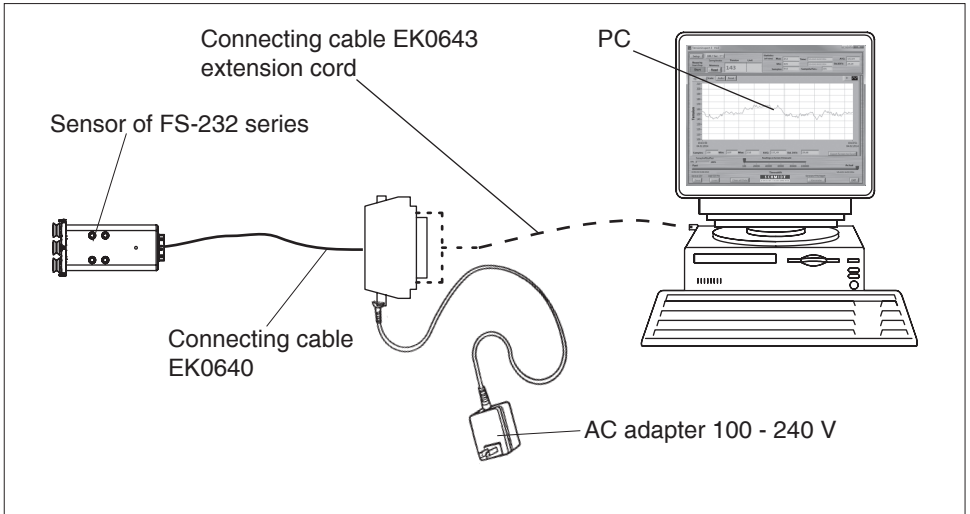

Code USB

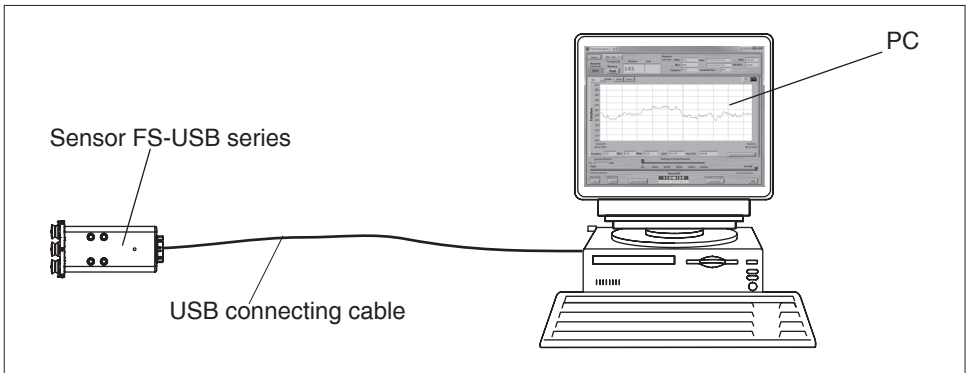

Die Stromversorgung des Sensors erfolgt über den PC

3.4 Internal adjustment of the sensors

General information:

If the sensor has been delivered with a display unit, the zero and gain adjustments should only be carried out with the supplied display unit.

All tension meters are calibrated with standard materials - such as polyamide monofilament (PA) - according to the SCHMIDT factory procedure; the material path is vertical. Any difference in process material size and rigidity from the standard material may cause a deviation of the accuracy.

In 95% of all industrial applications the SCHMIDT calibration has been proven to provide the best results and is used for comparative purposes.

If required you can also operate the sensors with a material path other than vertical. Should the process material differ significantly from the SCHMIDT calibration material in size, rigidity or shape, we recommend special calibration using customer supplied material. If the material path is other than vertical or if the process material deviates significantly from the SCHMIDT calibration material, you need to carry out static **zero** and **gain** adjustment as described in chapters 3.4.1 and 3.4.2.

3.4.1 Zero adjustment

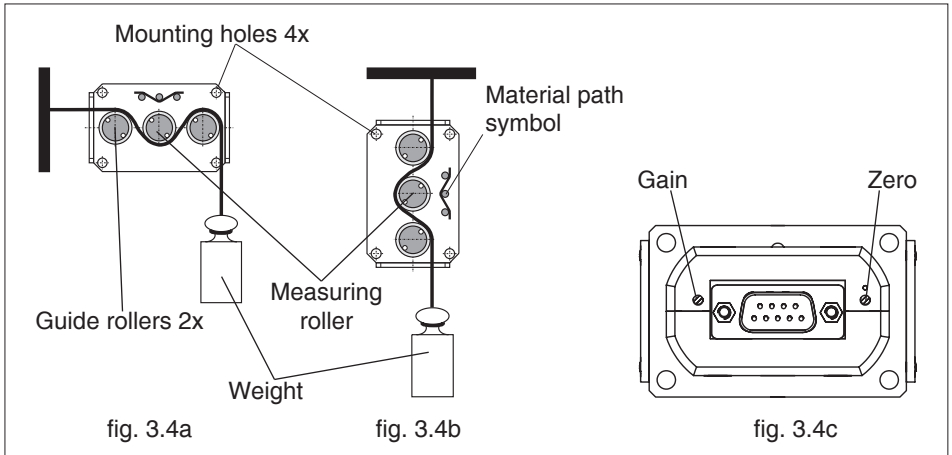

- Install the sensor in the desired position at the measuring location using the provided mounting holes.
- Allow approx. 10 minutes for thermal stabilization of the sensor.
- Thread the process material through the measuring and guide rollers, following the material path symbol on the front of the sensor.



When threading the process material through the rollers, follow the material path symbol on the front of the sensor. If a force is applied to the middle sensor roller in the incorrect direction, damage could result.



Since zero and gain adjustments are always performed statically, the readings may differ under dynamic load.

3.4.1 Zero adjustment (cont.)

- Hang a weight that corresponds to e.g. 10 % of the tension range from the process material.
- Start the measuring in the software
- Adjust the potentiometer, which you can reach through the zero hole in the housing, with a screwdriver (with a point width of max. 1.9 mm) until the software displays the corresponding value of 10 %,



Do not insert the screwdriver at an angle as this may damage the potentiometer.

3.4.2 Gain adjustment

Requirement: Zero adjustment carried out.

Thread the process material through the measuring and guide rollers, following the material path symbol on the front of the sensor.

- Hang a weight that corresponds to e.g. 95 % of the tension range from the process material.
- Start the measuring in the software
- Adjust the potentiometer, which you can reach through the gain hole in the housing, with a screwdriver (with a point width of max. 1.9 mm) until the software displays the corresponding value of 95 %,



Do not insert the screwdriver at an angle as this may damage the potentiometer.

4 The »Tension Inspect 3« program

4.1 System requirements

Computer:	PC
Operating system:	Windows 7 and higher (32/64 Bit)
Hard disk space:	Approx. 200 MB
Installation:	CD-ROM drive

4.2 Installing »Tension Inspect 3«



To be able to restore the original files in case problems occur after the installation, you should make a backup of your hard disk contents before you start installing. In no event will Hans Schmidt & Co GmbH be held liable for any data loss or damage.

1. Insert the CD-ROM with the »Tension Inspect 3« program into the CD-ROM drive.
2. Start the installation process by double-clicking the application file.

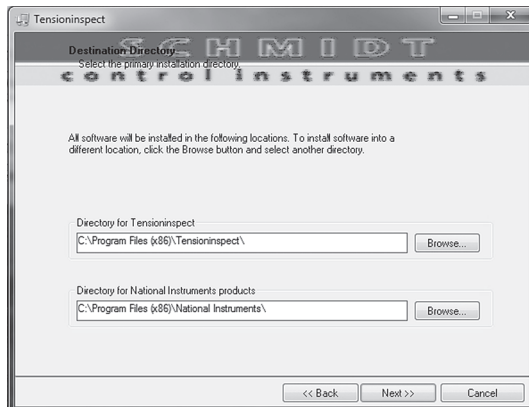

3. Follow the instructions on the screen, to install the software »Tension Inspect 3« and the corresponding USB driver.
4. At the end, click the “Finish” button, to finish the installation process.

4.3 Using installing »Tension Inspect 3«

- Double-click the »Tension Inspect 3«  icon to start the program.
The program window opens.

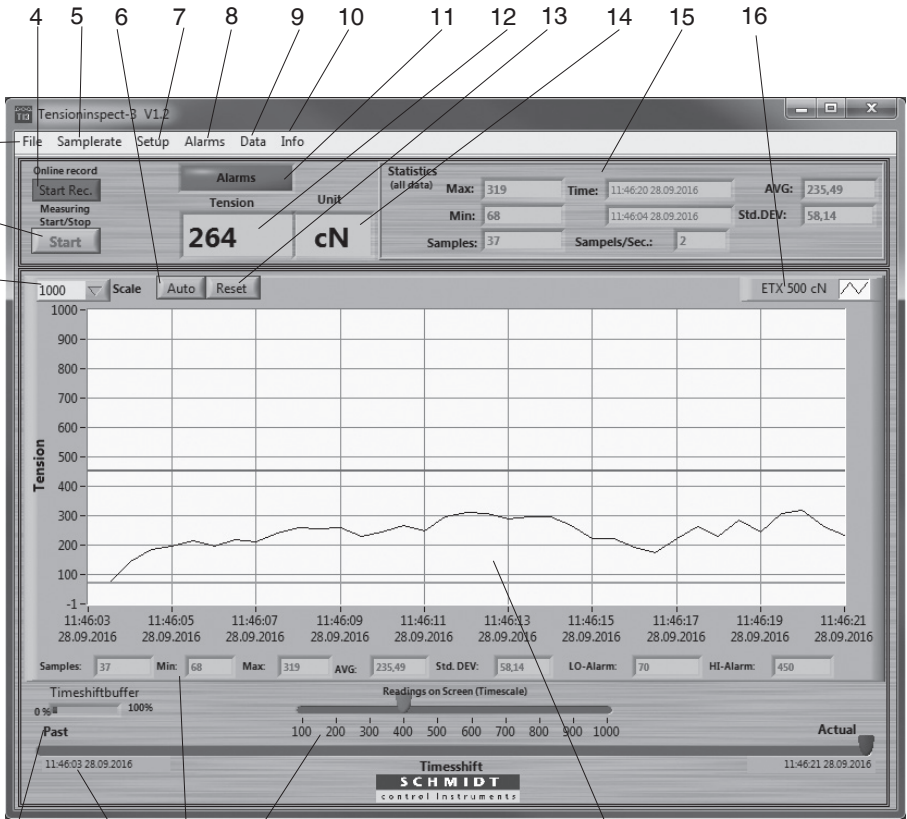

- | | | | |
|---|-----------------|------------------------|----------------------------|
| 1 | Menu file | Save as CSV | Chapter 4.3.6 |
| | Menu file | Load CSV | Chapter 4.3.6 |
| | Menu file | Esit | Close »Tension Inspect 3« |
| 2 | Button | Start/Stop | Chapter 4.3.2 |
| 3 | Choice box | Scale | Chapter 4.3.4 |
| 4 | Button | Start Rec. | Chapter 4.3.8 |
| 5 | Menu samplerate | Samplerate | Select the sampling rate |
| 6 | Button | Auto | Chapter 4.3.4 |
| 7 | Menu setup | Setup | Chapter 4.3.1 |
| 8 | Menu alarms | Enable Alarms | Chapter 4.3.3 |
| | Menu alarms | Show Alarms | Chapter 4.3.3 |
| | Menu alarms | Clear Alarms | Chapter 4.3.3 |
| 9 | Menu data | Clear Data | Clear all measuring values |
| | Menu data | Create HTML-Report | Chapter 4.3.5 |
| | Menu data | Export Screen to Excel | Chapter 4.3.5 |
| | Menu data | Memory Review | Not for FS series |

4.3 Using »Tension Inspect 3« (cont.)

10	Menu info		Information about »Tension Inspect 3«
11	Display	Alarms	Change to red, if the reading exceed or underrun the setpoint durring a measuring
12	Display	Tension	Current reading
13	Button	Reset	Chapter 4.3.4
14	Display	Unit	Unit of measure of the readings
15	Display	Statistics	Display of statistical values of the measurement
16	Display	Model	Display the connected unit
17	Display	Timeshift Buffer	Chapter 4.3.4
18	Display	Timeshift	Chapter 4.3.4
19	Display	Statistics Diagram	Display the statistical values, shown currently at the graph.
20	Display	Readings on Screen	Chapter 4.3.4
21	Display	Tension	Readings as graph, as well as the Hi/Lo set-points (only when activated)

4.3.1 Basic settings

Requirements:

- The required measuring unit is connected to the PC.
- The measuring unit is switched on

To edit the settings:

- Click on the menu Setup to open the dialog box.
- You can now either keep the default values preset in the input boxes or customize them for your specific requirements.
- The figure below shows the factory-preset defaults for a tension meter model ETX-500.

Enter text for the header describing the stored data

For testing the connection between the PC and the connected tension meter

Select the tension meter model

Transfer speed of the serial interface

Enter the COM port (1-4) to which the tension meter is connected

Activates recording of the values which exceed or underrun the Hi/Lo set-points

Determine the file for saving data of online recording

Select the tension range

Select the unit of measure.

Select the sample rate

Damping

Changing the background colour to black

Select the max. number of readings, displayed at the graph

Enter the Hi/Lo set-points

4.3.2 Start and stop the tension value display

Requirements:

- Click on Clear Data in the menu Data.
All readings shown in the Tension display, if any, are cleared.

Start:

- Click the Start button to activate the display of tension values.
The button shows Stop.

Tension value display:

Tension display	Current graph, as well as high set-point (red) and low set-point, if activated in the menu Alarms or Setup
Tension display	Current digital value
Statistics display	Continuously updated statistics
Statistics Diagram display	Continuously updated statistics, of readings, shown in the graph

Stop:

- Click the now Stop button.
The display of the tension values stops.
The button shows Start.

4.3.3 Hi/Lo set-points

»Tension Inspect 3« has a comparison function. Thereby the displayed value will be compared with the preset set-points. During exceeding or underrunning a set-point, the background of the display Tension change to red. The background of the display No Alarms change the colour permanently to red and shows now Alarms after exceeding or underrunning a setpoint for one time.

- | | |
|---------------|--|
| Enable Alarms | Activates recording of the values which exceed or underrun the Hi/Lo set-points |
| Show Alarms | By clicking Show Alarms at the menu Alarms the window „Alarm events“ will be opened. |

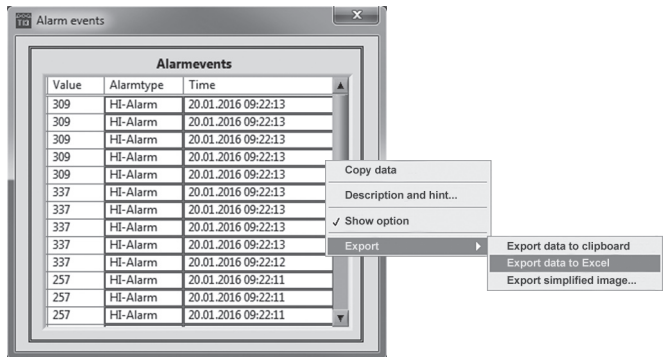

By opening the context menu in the window „Alarm events“ the values exceeding or underrunning the set-points can be exported to excel by using the menu items „Export“ and „Export data to excel“.

- | | |
|--------------|--|
| Clear Alarms | By clicking Clear Alarms in the menu Alarms all values in the window „Alarm events“ will be cleared. |
|--------------|--|

4.3.4 Graph adjustments

Scale	The maximal tension value of the diagram can be adjusted (Y-axis, starts at zero).
Auto	Automatic scaling of the Y-axis depending to the measured tension values.
Reset	Change of scaling from mode Auto to Scale
Readings on Screen (Timescale)	To set the number of readings to be shown in the diagram (X-axis). The scroll bar turns to red, if more readings are selected for the diagram than measured.
Timeshift Buffer	Indicates in % the fill level of the memory. The maximal numbers of readings will be set in the Setup.
Timeshift	To select the timeframe of a series of measurements, that should be displayed in the diagram. Is the setup Value of Readings on Screen bigger or equal to the recorded readings, the scroll bar cannot be moved.

4.3.5 Print and data transfer

Print:

- Click Create HTML-Report in the menu Data to open the print preview.
- Click the Print this Page button to open the printer setup box.

The print-out includes the statistical data of the series of measurements, the current displayed graph and the statistical values of the graph.

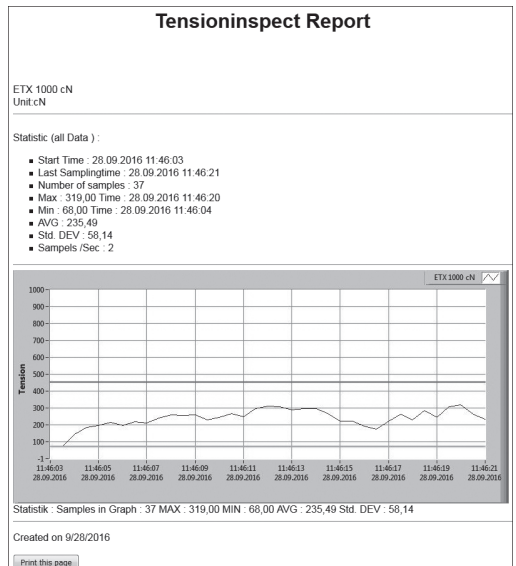

Data transfer:

- Clicking Export Screen to Excel in the menu Data copy the readings, which are displayed at the graph to an excel file (reading, date, time). With the infixed readings, a graph can be created in the Excel file.

4.3.6 Save and load the readings

Save:

- The statistical data, as well as the single readings of a measuring can be saved after the measuring ends as CSV file, by clicking Save AS CSV in the menu File.

Load:

- Click Load CSV in the menu File and open the required file.
The statistical data of the saved measuring, the graph and the statistical data of the graph are displayed in »Tension Inspect 3«

1 It is possible to add readings to an existing file. In this case open the file and start a new series of measurements. The new readings will be added in the diagram. After this store the complete CSV file again. If any readings are in the internal memory before opening the existing file, the internal memory will be overwritten.

4.3.7 Online recording

- Click first the button Start/Stop and afterwards Start/Stop Rec. to start the continuously data recording. The recorded data is now saved as CSV file. If the file reaches a size of 10 MB, a new CSV file will be generated automatically for further data acquisition and saving.
- By clicking the button Start/Stop the continuously data acquisition is paused. Clicking Start/Stop again will continue the recording. The data will be saved in the last CSV file.
- By clicking the button Start/Stop Rec. the continuously data acquisition is finished. After clicking Start/Stop Rec. again the recorded data will be saved in a new CSV file.
- The location for saving the files can be determined in the menu Setup.

5 PC communication

5.1 Windows terminal program

Commands for communication with a PC (polling)

The measured values can be transmitted to a personal computer. You can connect the computer to the connector of the sensor by using the EK0640 special cable which is available as an accessory, respectively a USB cable.

The pin assignment of the RS-232 connector is described in Chapter 2.3.

Requirement:

A communication program, such as Terminal or HyperTerminal must be installed and configured on the computer.

Setup commands:

ASCII Code	Function	Description
d	Avg value	current value
s	Fast Value	current value
z	zero	set zero
t	get information	request the information of the device (e. g. measuring range)

Reading the ring buffer (only USB):

ASCII Code	Function
g	integration 2 msec
h	integration 5 msec
i	integration 10 msec
j	integration 20 msec
k	integration 50 msec
l	integration 100 msec
m	integration 200 msec
n	integration 500 msec

Ring buffer response format:

@,Integrationtime in ms, comma separated values, CRLF

e. g. @,5,99,98,100,101,102,CRLF



The ring buffer contains max. 200 values

6 Service and maintenance

The instrument is easy to maintain. Depending on operating time and load, the instrument should be checked according to the locally valid regulations and conditions.

6.1 Verification of calibration and determination of repair costs

Flow chart for verifying the calibration of used tension meters, incoming and outgoing verification with Inspection Certificate 3.1 according to DIN EN 10204

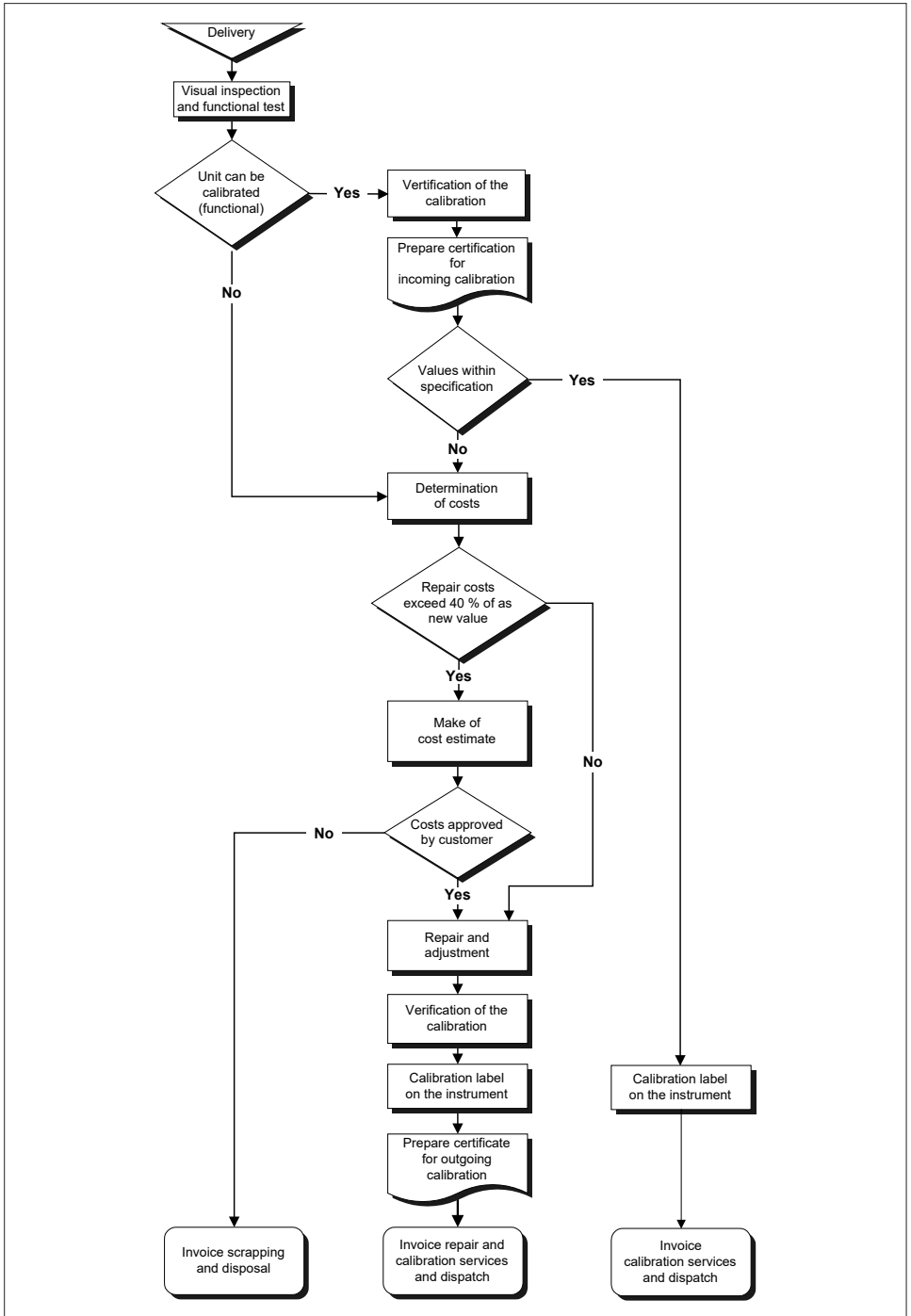

7 Cleaning

For cleaning the unit, do not use any



AGGRESSIVE SOLVENTS

such as trichloroethylene or similar chemicals.



NO WARRANTY OR LIABILITY

shall be accepted for damage resulting from improper cleaning.

8 Correspondence

Should you have any questions regarding the instrument or instruction manual, or their use, please indicate above all the following details which are given on the ID plate:

- 1) Model
- 2) Serial number

9 Repairs

Shipping instructions:

We kindly ask for return free of charge for us, if possible by airmail parcel. All occurring charges, if any (such as freight, customs clearance, duty etc.), will be billed to customer. For return from foreign countries, we ask you to include a proforma invoice with a low value for customs clearance only, e.g. 50 Euro, each and to advise the shipment in advance by fax or eMail.



To avoid unnecessary follow-up questions, and the resulting loss of time or possible misunderstandings, please return the instrument with a detailed fault description to our service department. Please indicate in your order whether you require an Inspection Certificate 3.1 according to DIN EN 10204.

Service address:

**Hans Schmidt & Co GmbH
Schichtstr. 16
D-84478 Waldkraiburg
Germany**

Notes:

SCHMIDT

control instruments

SCHMIDT-Test-Instruments
indispensable in production monitoring,
quality control and automation
We solve your measuring problems:



Tension Meter



Force Gauge



Torque Meter



Tachometer



Speed- and Lengthmeter



Electronic Lengthmeter



Stroboscope



Screen Printing Tension Meter



Thickness Gauge



Yarn Package Durometer and Shore Durometer



Sample Cutter



Balance



Moisture Meter



Leak Tester

More than 75 years - Worldwide -

Hans Schmidt & Co GmbH

Mailing address:

P. O. B. 1154
84464 Waldkraiburg Germany

Shipping address:

Schichtstr. 16
84478 Waldkraiburg Germany

Phone:

int. + 49 / (0)8638 / 9410-0

Fax:

int. + 49 / (0)8638 / 4825

int. + 49 / (0)8638 / 67898

e-mail:

info@hans-schmidt.com

Internet:

http://www.hans-schmidt.com