



Instruction Manual

Valid as of: 01.11.2018 • Please keep the manual for future reference!



Contents

1 Warranty and liability	4
1.1 Notices within the instruction manual	4
1.2 Responsibilities of the operating company	4
1.3 Responsibilities of the personnel	4
1.4 Informal safety measures	5
1.5 Training of the personnel	5
1.6 Intended use	5
1.7 Dangers in handling the device	5
1.8 Copyright	5
1.9 Declaration of conformity, RoHs II and WEEE registration	5
2 Available models	6
2.1 Specifications	6
2.2 Connecting the tension meter	7
2.3 Delivery includes	7
2.4 Unpacking	7
3 Operations	7
3.1 Notes before starting measurement	7
3.1.1 ID plate, CE mark, calibration label	8
3.1.2 Removing the filament guide	8
3.1.3 Mounting the filament guide	9
3.2 Operating and display elements	9
3.3 Setup	11
3.3.1 Charging the battery	12
3.3.2 Switching the tension meter on	12
3.3.3 Switching the tension meter off	12
3.4 Tension meter settings	12
3.4.1 Material menu	14
3.4.2 Password	14
3.4.3 Factory reset	15
3.5 Operation procedure	15
3.5.1 Zero adjustment of the measurement position	15
3.5.2 Inserting and removing material to be measured	16
3.5.3 Damping	16
3.5.4 Using the alarm function	17
3.5.5 Cal. adjustment	17
3.6 Creating a material characteristic	18
3.6.1 Setup for calibration	18
3.6.2 Calibration procedure	19
3.6.3 Verifying the calibration	21
3.7 Memory functions	22
3.7.1 Save data	22
3.7.2 Displaying the saved measured values	22
3.7.3 Deleting the saved measured values	22
4 Service and maintenance	23
4.1 Rollers	23
4.2 Replacing the rollers/ceramic pins	24

5	Cleaning.....	27
6	Verification interval	27
7	Correspondence	27
8	Repairs.....	27

1 Warranty and liability

In principle, the supply of the device is subject to our “General Conditions of Sale and Delivery.” These have been provided to the operating company on conclusion of the contract, at the latest.

Warranty:

- SCHMIDT tension meters are warranted for 12 months.
- Parts subject to wear, electronic components and measuring springs are not covered by the warranty. No warranty or liability will be accepted for bodily injury or property damage resulting from one or several of the following causes:
 - Misuse or abuse of the device.
 - Improper mounting, commissioning, operation and maintenance of the device (e.g. verification interval).
 - Operation of the device if any safeguards are defective or if any safety and protection precautions are not properly installed or not operative.
 - Failure to comply with the notices in the instruction manual regarding transport, storage, mounting, commissioning, operation, maintenance and setup of the device.
 - Any unauthorized structural alteration of the device.
 - Insufficient inspection of device components that are subject to wear.
 - Opening the device or improper repair work.
 - Disasters caused by the effects of foreign objects or by force majeure.

1.1 Notices within the instruction manual

The fundamental prerequisite for the safe handling of this device and its troublefree operation is the knowledge of the basic safety notices and safety instructions.

This instruction manual contains the most important notices for the safe operation of the device.

This instruction manual, in particular the safety notices, must be observed by any person who works with the device. In addition, the local valid rules and regulations for the prevention of accidents must be complied with.

The representations within the instruction manual are not true to scale.

The dimensions given are not binding.

General indications of direction, such as FRONT, REAR, RIGHT, LEFT apply when viewing the front of the device.

1.2 Responsibilities of the operating company

In compliance with the EC Directive 89/655/EEC, the operating company agrees to only permit persons to work with the device who:

- are familiar with the basic regulations on industrial safety and accident prevention and who have been trained in handling the device.
- have read and understood the chapter on safety and the warning notices in these instruction manual and have confirmed this with their signatures.
- are examined regularly on their safe and conscientious working method.

1.3 Responsibilities of the personnel

All persons who work with the device agree to perform the following duties before starting work:

- to observe the basic regulations on industrial safety and accident prevention.
- to read the chapter on safety and the warning notices in these instruction manual and to confirm with their signatures that they have understood them.

1.4 Informal safety measures

The instruction manual must always be kept on hand where the device is operated. Apart from the instruction manual, the generally and locally valid regulations on accident prevention and environmental protection must be provided and complied with.

1.5 Training of the personnel

Only trained and instructed personnel is permitted to work with the device. The responsibilities of the personnel must be clearly defined for mounting, commissioning, operation, setup, maintenance, and repair. Trainees may only work with the device under the supervision of experienced personnel.

1.6 Intended use

The device is intended exclusively to be used as a tension meter. Any other use or any use exceeding this intention will be regarded as misuse. Under no circumstances shall Hans Schmidt & Co GmbH be held liable for damage resulting from misuse.

The intended use also includes:

- Complying with all notices included in the instruction manual and observing all inspection and maintenance works.

1.7 Dangers in handling the device

The device was designed according to the state of the art and the approved safety standards. Nevertheless, its use may cause serious or fatal injury to the user or third persons, and/or an impairment of the device or of other material assets.

The device may only be applied:

- For its intended use in a faultless condition with regard to the safety requirements.
- Malfunctions that could impair safety must be remedied immediately.
- Personal protective equipment must be used according to the EC Directive 89/686/EEC.



The device must not be operated in potential explosive areas and must not come into contact with aggressive substances.

1.8 Copyright

The copyright on these instruction manual remains with the company Hans Schmidt & Co GmbH.

These instruction manual is intended for the operating company and its personnel only. They contain instructions and notices that may only be reproduced on the prior written permission of

Hans Schmidt & Co GmbH

and under indication of the complete reference data.

Violations will be prosecuted.

1.9 Declaration of conformity, RoHs II and WEEE registration

In compliance with the EU Directives 2014/30/EU and 2011/65/EU



Hans Schmidt & Co GmbH is registered in compliance with the German Electrical and Electronic Equipment Act (ElektroG) under WEEE Reg. No. DE 48092317.

2 Available models

1 The standard series is also available with the following modifications (customized versions): - Special calibration using customer supplied material.

Model	Tension Ranges cN	*Measuring Head Width mm	**SCHMIDT Calibration
ETB-100	0.3 - 100.0	24	PA: 0.20 mm Ø
ETB-200	2.0 - 200.0	24	PA: 0.20 mm Ø
ETB-500	2.0 - 500.0	24	PA: 0.20 mm Ø
ETB-1000	3 - 1000	38	PA: 0.30 mm Ø
ETB-2000	3 - 1000	38	PA: 0.50 mm Ø
ETPB-100	0.3 - 100.0	22	PA: 0.20 mm Ø
ETPB-200	2.0 - 200.0	22	PA: 0.20 mm Ø
ETPB-500	2.0 - 500.0	22	PA: 0.20 mm Ø

* Outer distance between outside guide rollers / pins

** Suitable for 95% of all applications. PA = Polyamide Monofilament.

If the material to be measured differs significant from the SCHMIDT calibration material in diameter, rigidity, shape, etc., we recommend calibration using customer supplied material. For this purpose a material sample of about 5 m should be supplied.

International unit of tensile force: 1 cN = 1.02 g = 0.01 N

ETB-100 to ETB-500: Calibration with running filament approx. 100 m/min

ETB-1000 and ETB-2000: Calibration with static filament

ETPB: Calibration with approx. 60 m/min

2.1 Specifications

Calibration:	According to SCHMIDT factory procedure
Units of measure:	cN, g, N, lb, user selectable
Accuracy:	± 1 % full scale ± 1 digit (typical ± 0.5 % full scale)
Overrange:	10 % full scale, without accuracy guarantee
Overload protection:	200 % full scale
Measuring principle:	Strain gauge bridge
Meas. roller deflection:	0.5 mm, max.
Signal processing:	Digital
Damping:	Moving electronic (averaging)
Sampling rate internal:	Approx. 1 KHz
Sampling rate:	200 Hz, 2 Hz: AVG, MIN and MAX
Display update rate:	2 times per second
Display:	Colour TFT 128 x 160
Memory:	Average, last value, MAX, MIN
Communication frequency:	max. 200 readings/sec
Temperature coefficient:	Gain: less than ± 0.01% full scale/°C
Temperature range:	10 - 45° C
Air humidity:	85 % RH, max.
Auto power off:	Automatic after approx. 3 min. of non-use
Power supply:	LiPo accumulator (20 h continuous use, 3 ½ h charging time), USB AC adapter 100 ... 240 V AC with 4 adapters (EU/USA/UK/AUS-NZ)
Housing material:	Aluminium
Housing dimensions:	182 x 54 x 41 mm (L x W x H)
Weight net (gross):	Approx. 310 g (1220 g)

2.1 Specifications

ETB guide rollers:

V-Groove	Line Speed m/min ... max.	Roller Material
Standard	2000	Aluminium hard chromed (up to 500 cN)
Standard	2000	Hard-coated aluminium (from 1000 cN)

ETPB guide pins:

V-Groove	Line Speed m/min ... max.	Roller Material
Standard	6000	Oxide ceramic

2.2 Connecting the tension meter



The requirements of the CE specification are only complied with if the tension meter is equipped and operated with equipment supplied by Hans Schmidt & Co GmbH. Certification to the CE specification does not extend to, and shall be invalid for any other combination. For damage resulting thereby we assume no liability.

2.3 Delivery includes

- Tension meter with accumulator
- USB AC adapter with 4 adapters (EU/US/UK/AUS-NZ)
- USB cable
- Certificate of compliance with the order 2.1 according EN 10204
- Instruction manual
- Carrying case

2.4 Unpacking

Unpack the tension meter and inspect it for any shipping damage. Notices of defect must be announced immediately, in writing, at the latest within 7 days on receipt of the goods.

3 Operations

3.1 Notes before starting measurement



Have you read and understood the instruction manual, in particular chapter 1 “Warranty and liability” ?

You are not permitted to operate the tension meter before doing so.

Before working with the instrument you must put on your personal protective clothing, if necessary. For example, eye protectors, gloves, etc.
To avoid damage do not move the center roller by hand.

Tensions that exceed the tension range of the instrument by more than 100 % may cause permanent damage to the measuring spring and must be avoided under any circumstances.

3.1.1 ID plate, CE mark, calibration label

- 1** • The ID plate with the CE mark and the serial number as well as the calibration label (optional) are provided on the backside of the instrument, the SCHMIDT Quality Seal is provided on the right side.

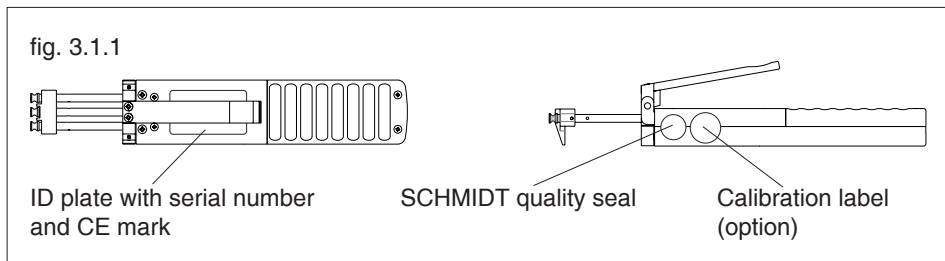

3.1.2 Removing the filament guide

(see also chapter 4.2)

The tension meter is supplied with a filament guide for fast and easy material acquisition. For application in hard-to-reach areas with limited access space, you can remove the filament guide.

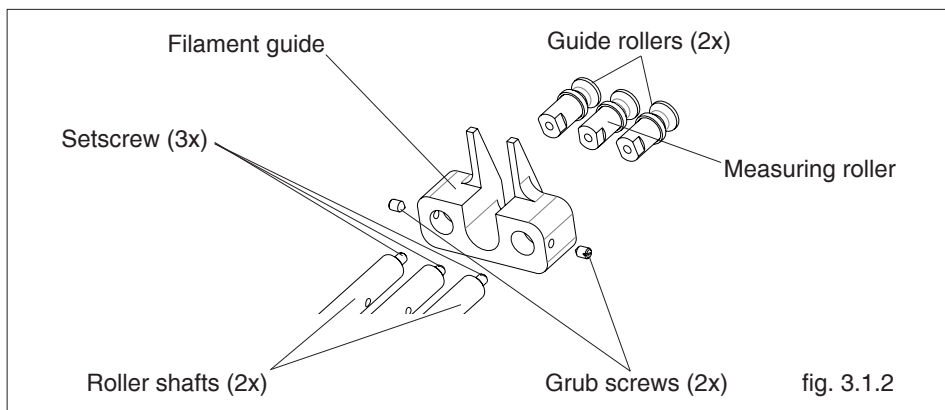

Removal:

- Loosen the grub screws (2x) with the supplied screwdriver (blade width 1.5 mm).
- Unscrew and remove the guide rollers (2x) with the supplied open end wrench (jaw width 4 mm).
- Slip the filament guide off the roller shafts.
- Screw the guide rollers (2x) back on to the roller shafts and carefully tighten them with the supplied open end wrench (jaw width 4 mm) until hand-tight.

3.1.3 Mounting the filament guide

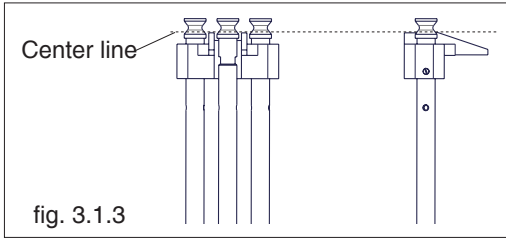

Mounting:

- Unscrew and remove the guide rollers (2x) with the supplied open end wrench (jaw width 4 mm).
- Slip the filament guide on to the roller shafts.
- Screw the guide rollers (2x) back on to the roller shafts and carefully tighten them with the supplied open end wrench (jaw width 4 mm) until hand-tight.
- Push the filament guide forward far enough to ensure that the rollers do not rub against the filament guide and that the process material can slide unhindered from the filament guide into the roller grooves (fig. 3.0.2 center line).
- Carefully tighten the grub screws (2x) with the supplied screwdriver until hand-tight.

3.2 Operating and display elements

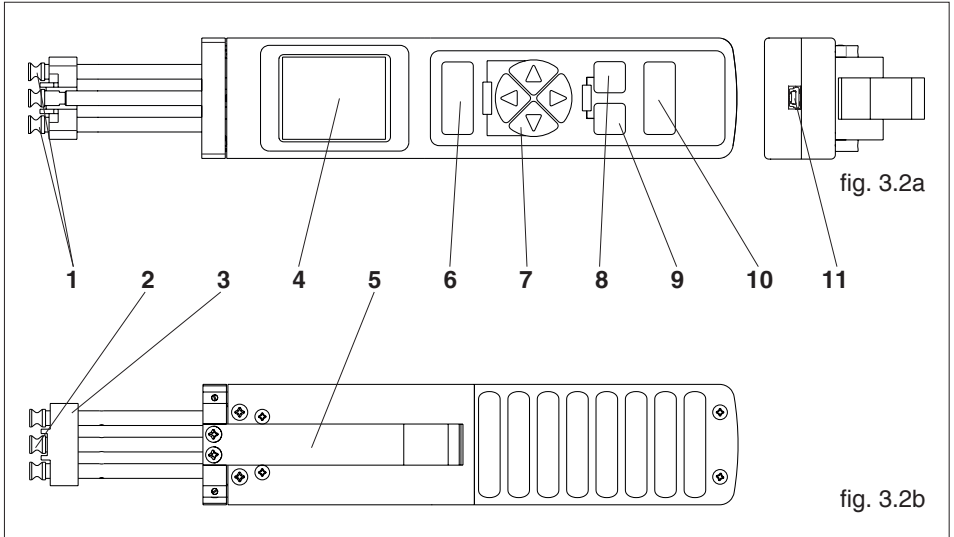

- | | |
|--------------------|---------------------|
| 1 Guide rollers | 7 Arrow key |
| 2 Measuring roller | 8 „SET/DAMP“ key |
| 3 Filament guide | 9 „ESC/EXIT“ key |
| 4 Display | 10 „POWER/ZERO“ key |
| 5 Lever | 11 Power connector |
| 6 „MEMORY“ key | |

3.2 Operating and display elements

Numeric display

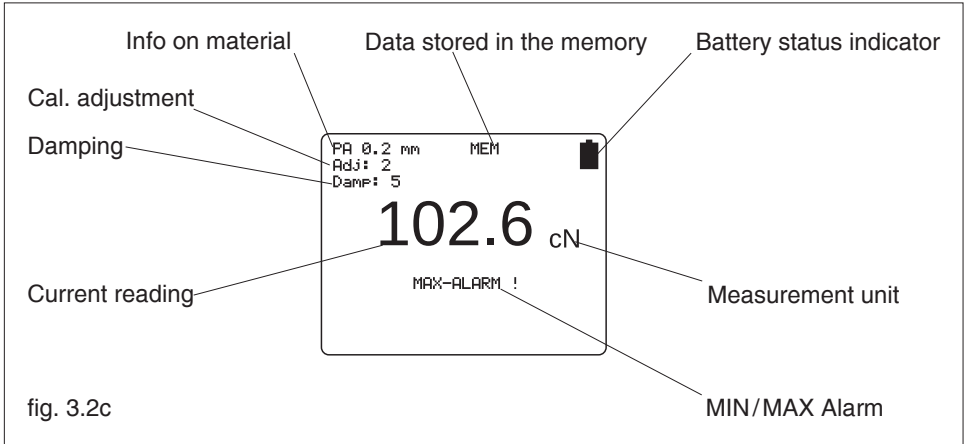

Display with bargraph

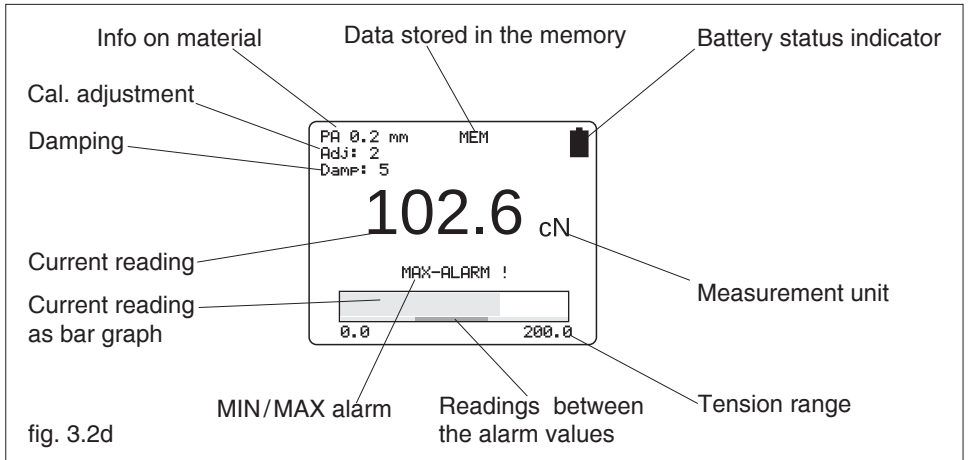

3.2 Operating and display elements

Graphic display

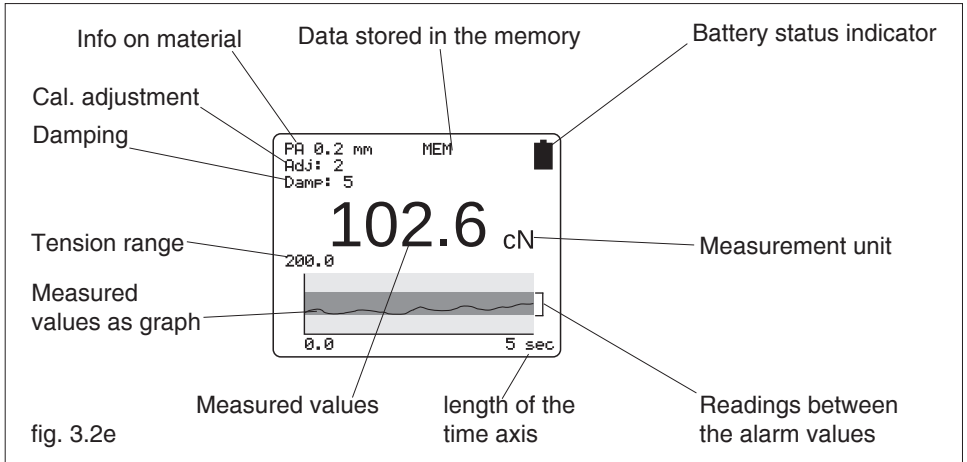

1

The Y-axis can be scaled with the ▲ and ▼ buttons.

3 Scalings: total measuring range, set limits range plus approx. 1/3 of MAX.-alarm value and minus approx. 1/3 of MIN.-alarm value, if limit values are entered and the damping is not activated.

With the ◀ or ▶ button the X-axis can be scaled. The setting range is 2 to 60 sec.

The scaling can also be changed during the measurement, whereby values already displayed are deleted when the X-axis is changed.

3.3 Setup

The tension meter is delivered with a built-in rechargeable LiPo battery, which has been charged at the factory. The tension meter can only be switched on if the battery is still working, i.e. if the battery has enough charge. If the instrument does not power up or if the battery level indicator shows a low charge  after power-up (chapter 3.3.2), the battery needs to be recharged.



To ensure maximum battery life, avoid discharging it completely or charging it frequently for short periods. The battery should not be stored for an extended period of time when empty. After a maximum storage period of one year, the battery has to be recharged.

3.3.1 Charging the battery



The battery can only be charged at a temperature between +5 °C and +45 °C.

Before you connect the AC adapter, verify that the supply voltage is correct (100 V - 240 V).

Hans Schmidt & Co. GmbH provides no warranty or liability for any damage resulting from the use of AC adapters from other manufacturers.

To charge the battery, remove the rubber stopper from the USB interface. Then connect the cable of the AC adapter to the USB output.

The battery can also be charged by connecting the USB cable to a PC.

When the battery is fully charged, the battery level indicator will be shown full .

The charging time is approx. 3 ½ hours (using the AC adapter).



Battery overcharging is not possible

3.3.2 Switching the tension meter on

Press and hold the  button (for approx. 1 sec) until the display shows the measuring range, the software and hardware versions, e.g. E 1.0, and then "0".

During startup, the tension meter performs an automatic zero adjustment. If the tension meter does not display zero, perform a manual zero adjustment procedure (chapter 3.5.2).

Holding the  button makes the display freeze so that you can read the measuring range and the software and hardware versions.



While switch-on the tension meter, make sure not to move it. Otherwise, the automatic zero adjustment will be faulty.

3.3.3 Switching the tension meter off

Automatic switch-off (if enabled):



- After an idle period of 3 minutes, the tension meter switches off.



Manual switch-off:



- Press and hold the  button for 5 seconds.



3.4 Tension meter settings

- Press the  and  buttons simultaneously to access the main menu.

- The  and  buttons can be used to select the various menu items of the main menu, the submenus and the settings menus.

- Press the  button to open the selected menu; by pressing the  or  button you can close the menu without saving changes.

- In menus with multi-digit fields (e.g. date) use the  and  buttons to move forward and backward between digits.

- Press the  button to save the settings and exit the settings menu or press the  button to exit the current menu without saving.

- To exit the main menu press the  button.

3.4 Tension meter settings

Main Menu	Submenu	Settings Menu	Description
Material	[1] to [4]		Chapter 3.4.1 Material-Set-up
Cal. Adjustment	—	[- 10 %] - [+ 10 %]	Chapter 3.5.6
Display chapter 3.2	—	[numeric] [Bargraph] [Graphic]	<ul style="list-style-type: none"> Measured value displayed as number and alarm monitoring Measured value displayed as number, bar graph trend display and alarm monitoring Measured value displayed as graphical trend, measured value/limit values as graph
Alarms	—	[ON] , [OFF]	Activate/deactivate the alarm for all calibrations. The alarm of a material characteristic is only active if the [Alarm] menu item in Material Setup is activated as well.
Display Settings	Backlight	[ON], [AUTO]	Switch the display light on or off. With the AUTO setting, the light switches on and off automatically depending on the ambient light.
	Brightness	[1], [2] , [3]	Set the display brightness.
	Colortheme	[white] , [black]	A white or black display background can be adjusted
	Screen Rotation	[0°], [90°], [180°]; [270°] , [AUTO]	To set the display orientation to be fixed or to automatically adapt to the current orientation of the device.
System Settings	Tension Unit	[cN] , [g], [lb], [N],	Set the measurement unit. The available units may vary depending on the measuring range of the device.
	Auto Power Off	[ON] , [OFF]	Toggle the „Auto Power off“ function on and off.
	Language	[EN] , [DE]	Select between the english and german user language.
	Date/Time	[Time], [Date], [Timeformat]	Set the time, date, and date/time format.
	Password	[0] , [1], [2], [3]	Chapter 3.4.2
	Factory Reset		Reset to the factory settings.

Factory settings are illustrated bold

3.4.1 Material menu

In the material menu you can make the settings for the selected material characteristics and perform the calibration. To perform the calibration, the weights for the selected calibration points must be available.

Material Setup	Submenu	Settings Menu	Description
No. of the characteristic material curve 1 - 4	—	[character], [numbers], [special character]	to enter a name for the selected material characteristic. The name can also be adjusted by using the provided software
Damping	—	[1] - [9]; [5]	Chapter 3.5.3
Alarms	—	[ON] , [OFF]	To activate or deactivate the alarm function for the material characteristic.
High limit	—	[0000] - [9999]	If the set limit value is exceeded, the display reads MAX-ALARM.
Low limit	—	[0000] - [9999]	If the value falls below the set limit value, the display reads MIN-ALARM.
Calibration (Chapter 3.6.2)	Start		To perform a calibration, follow the instructions shown on the display.
	Cal. Points	between [5 %] and [90 %] of the tension range	Set three calibration points for which a calibration should be performed.
	Weights	[cN] , [g]	Set the unit of the calibration weights used.

Factory settings are illustrated bold

3.4.2 Password

By setting a password, you can block the access to some menu parts for unauthorized users. Therefor are 3 protection levels:

- 0 All menus are accessible (Factory setting)
- 1 The system setting menu is locked
- 2 The material, system setting, memory setting and cal. adjustment menus are locked
- 3 All menus are locked.

Apply the password protection

- Select the menu password (chapter 3.4)
- Insert a password and choose a protection level
- Exit the main menu, to apply the password protection

• **1** The factory setted password is „0000“
**If you forgot the password, please contact
Hans Schmidt & Co GmbH to request the master password.**

3.4.3 Factory reset

A factory reset resets the tension meter to its original manufacturer settings. This procedure will delete all settings, including any customer-defined material characteristics (calibrations); the factory calibration, however, will be kept.



Customer calibrations will be deleted.

3.5 Operation procedure

Requirements:

- Switch the tension meter on (chapter 3.3)
- Define the required tension meter settings (chapter 3.4)
- Select the desired material characteristic (chapter 3.4.1)
- Bring the tension meter into the desired measuring position and carry out a zero adjustment as described in chapter 3.5.1, if required.

3.5.1 Zero adjustment of the measurement position

Each time the measurement position is changed, the tension meter will automatically perform a zero adjustment.



**If the tension meter does not display zero in its measuring position, perform a manual zero adjustment procedure.
For this purpose, no material to be measured must have been inserted yet!**

Requirements:

- The tension meter has been switched on as described in chapter 3.3.2.

To carry out zero adjustment:

- Bring the tension meter into the desired measuring position and make sure not to move it.

- Press the  button.

The Display momentarily shows  and then switches to .

The tension meter is now adjusted to its new measuring position and ready to take measurements.

3.5.2 Inserting and removing material to be measured

Inserting the material to be measured:

- Press the lever to tilt the outer guide rollers sideways.
- Thread the material to be measured through the measuring and guide rollers (filament guide).
- Slowly release pressure on the lever until the guide rollers return to their original position.

It is important to assure that the material to be measured runs smoothly between the measuring and guide rollers.

Measuring:

The display now shows the measured tension values.

Removing the material to be measured:

- Press the lever and remove the material to be measured.
- Slowly release pressure on the lever until the guide rollers return to their original position.

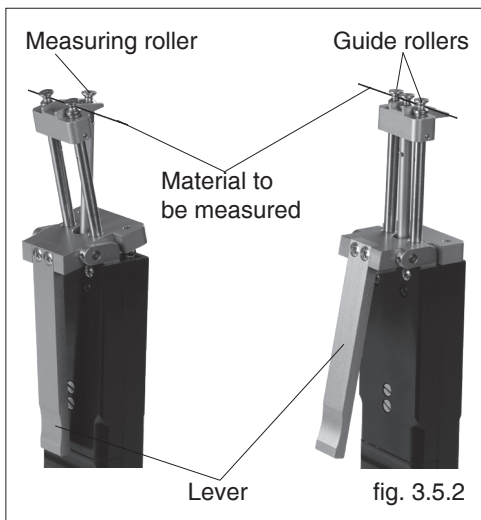

3.5.3 Damping

Feature to be used for tensions that vary strongly

In the damping menu (chapter 3.4.1), you can specify separate damping factors for each material characteristic. Back in the display mode, press the **SET DAMP** button to activate or deactivate the damping function. This is recommended if the displayed values vary strongly. Press the **▲** button to increase the damping value or the **▼** button to decrease it.

1 Changes made to the damping factor using the arrow keys are not saved permanently in the material characteristic. If you disable the damping feature or select a different material characteristic, the damping factor will be reset to the value originally saved for the material characteristic.

The factory setting for the damping factor is 5. The average shown on the display is calculated as follows:

$$\frac{5 \text{ old measured values} + 4 \text{ new measured values}}{9}$$

Damping can be changed in 9 steps from 01 = low damping:

$$\frac{1 \text{ old measured value} + 8 \text{ new measured values}}{9}$$

to 9 = high damping:

$$\frac{8 \text{ old measured values} + 1 \text{ new measured value}}{9}$$

3.5.4 Using the alarm function

Requirements:

In the Material Setup menu, make sure that the MIN and MAX limit values have been set for each material characteristic.

The limit value alarm has to be enabled in the main menu.

3.5.5 Cal. adjustment

By performing a calibration adjustment, you can adjust a material characteristic calibrated for a particular material to a different material or diameter without creating a new material characteristic.

Requirements:

- Prepare the measuring setup as shown in fig. 3.5.5a.
- Select the desired material characteristic (chapter 3.4.1).
- Move the tension meter into the desired measuring position and carry out a zero adjustment, if required.

Adjusting:

- Select the „Cal. Adjustment“ menu item from the main menu (fig. 3.5.5b)
- Insert the material to be measured (chapter 3.5.2) and push the thumbpiece into the measuring position.
- Press the ▲ or ▼ key to perform the calibration adjustment until the value on the display corresponds to the weight suspended to the material.
The adjustment can be performed in 1 % steps within the range from +10 % to -10 %.
- Press the  button to save the determined value.

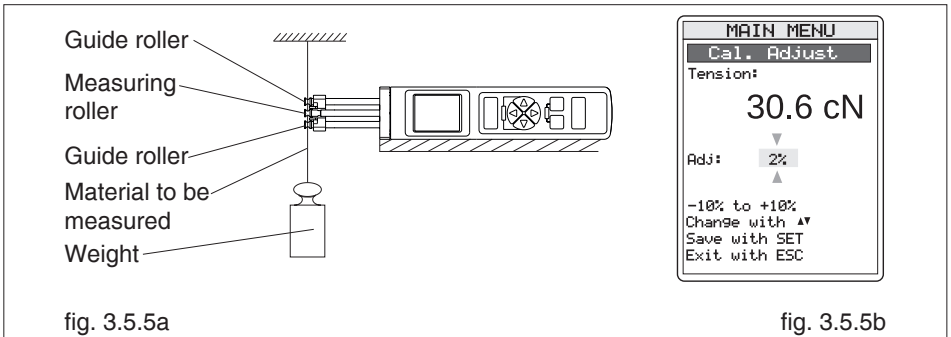

Please note that this is a general value. So determine it separately for each material characteristic and note it down for later reference. It is not possible to save it per material characteristic.

To disable calibration adjustment, reset the value to 0 % in the „Cal. Adjustment“ menu.



The calibration adjustment has to be conducted with the weight unit, that is adjusted in the menu „tension unit“ and must be carried out with weights corresponding to the chosen unit.

3.6 Creating a material characteristic

The tension meter has been calibrated dynamic on material 1 according our SCHMIDT procedure for a vertical material path and cannot be deleted or overwritten. The material and diameter is given in chapter 2. Factory calibrations using customer supplied materials follow the same procedure. In this case, however, the calibration on Schmidt material 1 is omitted. fig. 3.6.1a shows a measuring setup for the dynamic calibration, while fig. 3.6.1b shows a measuring setup for the static calibration.

- 1 The material characteristics has been preset in the factory and cannot be overwritten. For these material characteristics, you can only change the damping factor, the alarm function setting, and the limit values.

3.6.1 Setup for calibration dynamic calibration

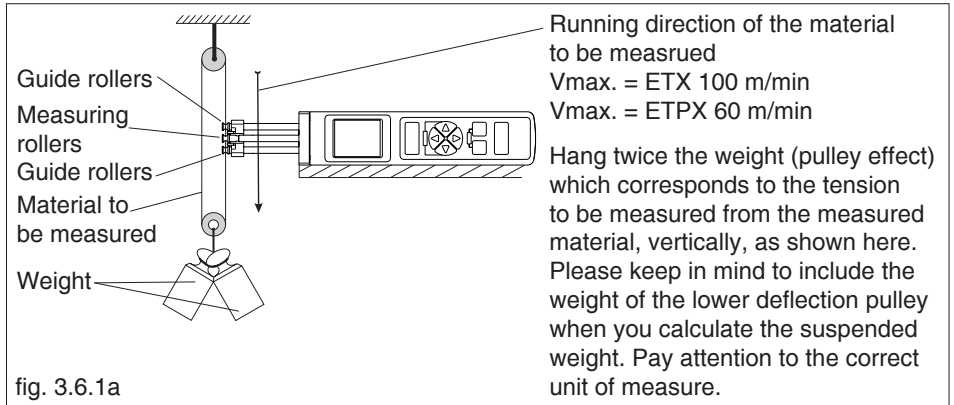

Hang twice the weight (pulley effect) which corresponds to the tension to be measured from the measured material, vertically, as shown here. Please keep in mind to include the weight of the lower deflection pulley when you calculate the suspended weight.

The models ETB-1000 and ETB-2000 must not be calibrated dynamically, because the measurement reliability cannot be guaranteed in this case.

static calibration

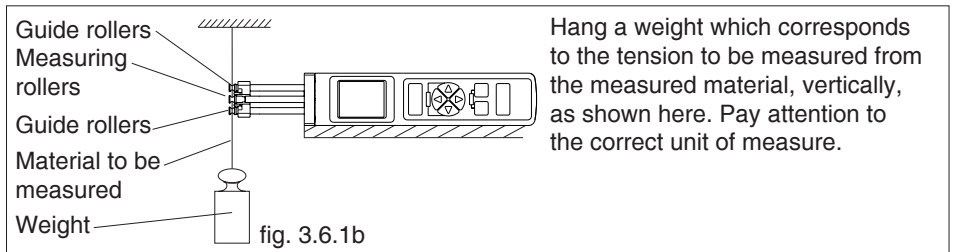

- 1 The tension meter has been calibrated dynamically (fig. 3.6.1a) according to the SCHMIDT factory procedure. Therefore, differences may occur between static and dynamic readings.

3.6.2 Calibration procedure

Calibrations of the tension meter are performed according to the SCHMIDT factory procedure using weights that correspond to 10 %, 50 %, and 90 % of the measuring range. In 95 % of all industrial applications, the SCHMIDT calibration has been proven to provide the best results. In particular, it is suitable for comparative purposes. If the material to be measured differs significantly from the SCHMIDT calibration material in material type, diameter, rigidity, shape, etc., we recommend to perform a calibration using customer-supplied material. In addition to the factory-preset material, you can save up to 3 additional materials.

Calibration units and calibration points

- The device can be calibrated in centinewton (cN) or gram (g). Although the unit of the calibration weights has to correspond with the unit chosen in the menu „calibration“
- For the calibration of the tension meter, three calibration weights are used. For example, if you select 10 %, 40 %, 70 % for the weights for the static calibration must correspond to 10 %, 40 % and 70 %, for the dynamic calibration 20 %, 80 % und 140 % of the measuring range.

In this example, you need the following weights for the ETX-100:

Static calibration in Newton: 10 cN, 40 cN, and 70 cN

Static calibration in Gram: 10 g, 40 g, and 70 g

Dynamic calibration in Newton: 20 cN, 80 cN, and 140 cN

Dynamic calibration in Gram: 20 g, 80 g, and 140 g

i The measured values are displayed in the unit set in the „Settings“ menu, independent from the unit that was used to calibrate the material characteristic. So that they are available when you verify the calibration later or repeat the calibration after a factory reset.

e. g.

Material to be measured	Unit	Calibration points
Yarn	cN	5 %, 50 %, 90 %

To perform the calibration procedure

- Select a new material or edit an existing one (by re-entering the values) from the „material“ menu.
- Enter a designation (you can use the software supplied with the tension meter alternatively).

i While performing the calibration, the tension meter must be fixed in such a way that the material to be measured runs smoothly between the guide rollers and the measuring roller.
The display gives detailed information on the calibration.

3.6.2 Calibration procedure

In the „Material“ menu, select Calibration.



Step 1:

Set the calibration points and weights, e.g. in Newton using the calibration points 10 %, 40 %, and 70 % of full scale

Start: Select the Start menu item.

Alternative calibration points: 5 %, 45 %, 90 % 10 %, 50 %, 90 %
5 %, 50 %, 90 % 10 %, 40 %, 70 %
10 %, 45 %, 90 %

We recommend to use the 10 %, 50 %, 90 % setting for an initial calibration. If the measured values are not accurate enough when you check the calibration, repeat the calibration using other calibration points.

We recommend that you align the middle of the tension range to be measured with the middle calibration point.



Step 2:

Perform a zero adjustment with the tension meter in its measuring position



Step 3:

Calibrate calibration point 1
Insert material to be measured



Step 4:

Calibrate calibration point 2



Step 5:

Calibrate calibration point 3



Once you have completed the calibration, make sure to verify it as described in chapter 3.6.3. In case of a large deviation, repeat the calibration or select different calibration points.

3.6.3 Verifying the calibration

When verifying the calibration, make sure to select the same material, calibration position and calibration points as used for creating the associated material characteristic. Otherwise, the precision of the measurements will not be sufficient.

The tension meter has been calibrated on material 1 according our SCHMIDT procedure for a vertical material path and cannot be deleted or overwritten. The diameter and material is given in chapter 2. Calibrations of the tension meter are performed according to the SCHMIDT factory procedure using weights that correspond to 10 %, 50 % and 90 % of the measuring range.

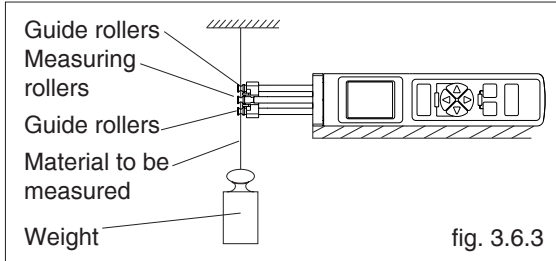

- Attach a weight vertically to the material to be measured that corresponds to the tension to be measured (make sure to select the correct unit). The weight must hang freely. (Always use a fresh portion of the material to be measured.)
- Insert the material as described in chapter 3.5.2.



Do not let the lever snap back as this could affect the calibration and damage the instrument.

- Before verifying the calibration, move the instrument slowly up and down to compensate for any mechanical friction losses and thus ensure repeatability of the measurements.
- The tension value shown on the display should be equal to the mass of the suspended weight.

If the verification of the calibration shows a deviation beyond the allowable tolerance so that reliable operation is no longer possible, the instrument needs to be re-calibrated or returned to the factory for repair.

3.7 Memory functions

You can store and display the statistics of one measuring series (last measured value, the average, the minimum and maximum measured values, the peaks, the standard deviation).

3.7.1 Save data

- Press the **MEMORY** button to start recording the measured values.
- While recording is in process, "Rec S" flashes on the display.
- Press the **MEMORY** button again to stop recording.
- To save the recorded data, press the **SET DAMP** button (the display shows "Mem").
Data, stored in the memory before, will be overwritten.
- Press the **ESC EXT** button to stop recording the measured values without saving

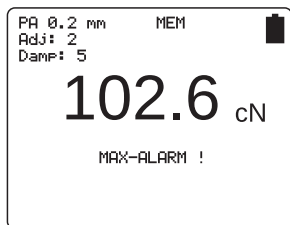

fig. 3.7.2.1

i If the memory already contains data, a message will inform you that the data will be deleted.

3.7.2 Displaying the saved measured values

- Press the ◀ and ▶ buttons simultaneously to display the saved data.

The display will only show statistical values:

- Name of the material to be measured
- Date and time of storage
- Last reading
- Average
- Max.
- Min.
- Standard deviation (Std dev)
- Number of measured values (Records)

3.7.3 Deleting the saved measured values

If data is saved in the tension meter, the display shows "Mem" and indicates the free memory space.

Deleting data:

- Press the ◀ and ▶ buttons simultaneously
- Then press the **Power ZERO** button and confirm with the **SET DAMP** button.
This clears the memory.

4 Service and maintenance

The tension meter is easy to maintain.

Depending on operating time and load, the instrument should be checked according to the locally valid regulations and conditions (as described in chapter 3.6.3). The use of other test methods than the procedure described in chapter 3.6.3 may cause deviating measuring results.

4.1 Rollers

For example:

To order spare rollers:

Model: ETB-100 (given on rear side of tension meter)

Serial number: 420 - 88888 (given on rear side of tension meter)

Standard rollers:

Model number: R542017 (up to 500 cN)

Model number: R542006 (from 1000 cN)

Delivery: 1 set (3 pcs.) of spare rollers 2000 m/min

To order ceramic pins:

Model: ETPB-100 (given on rear side of tension meter)

Serial number: 420 - 88888 (given on rear side of tension meter)

Ceramic pins:

Model number: R542020

Delivery: 1 set (3 pcs.) of spare ceramic pins 6000 m/min

4.2 Replacing the rollers/ceramic pins



Replacing rollers by ceramic pins or ceramic pins by rollers can only be performed at the manufacturer's facility.

Required tools:

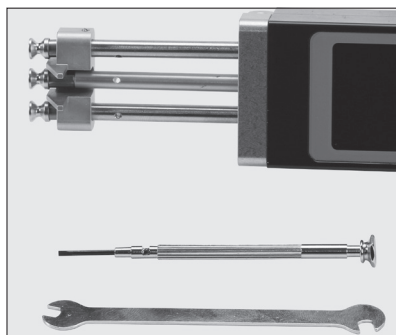

fig. 4.2a

Screwdriver with 1.5 mm blade width.
Open end wrench with 4 mm jaw width.

To remove the filament guide:

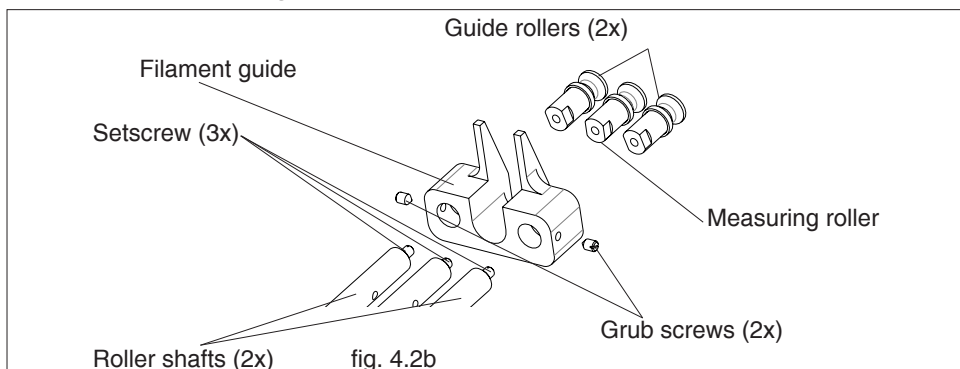

fig. 4.2b

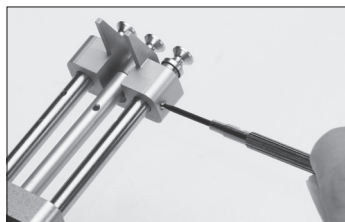

fig. 4.2c

- Loosen the grub screws with the supplied screwdriver (1.5 mm blade width).

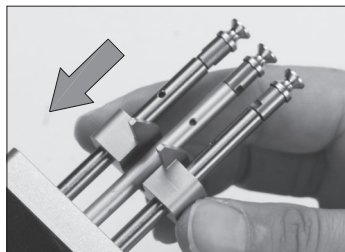
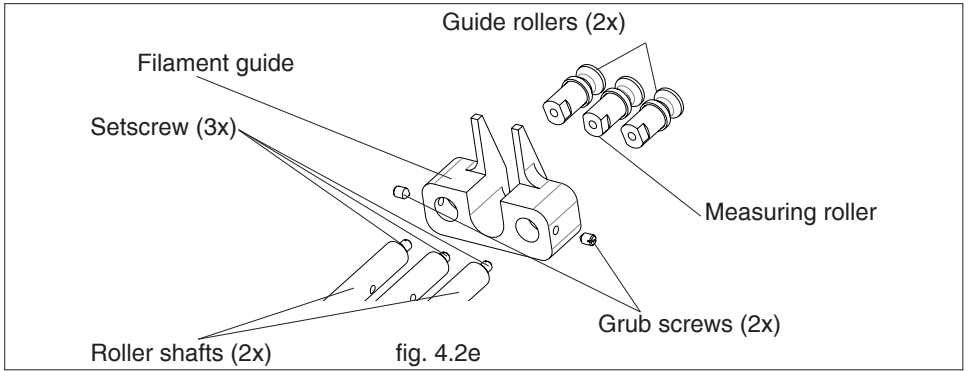

fig. 4.2d

- Slide the filament guide down the Roller shafts in the direction of the arrow.

4.2 Replacing the rollers/ceramic pins (cont.)



To remove the used rollers:



- Loosen the rollers with the supplied open end wrench (4 mm jaw width).

i Should any of the three threaded studs be damaged, replace it by one of the threaded studs supplied with the new rollers.

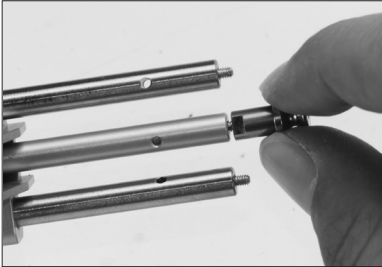

- Screw off the rollers.



When loosening the rollers, steady the roller bolts with the supplied screwdriver to prevent loosening of the roller shafts.

To mount the new rollers:



- Screw the new rollers to the roller shafts.

4.2 Replacing the rollers/ceramic pins (cont.)



fig. 4.2i

- Carefully tighten the new guide and measuring rollers with the supplied open end wrench (4 mm jaw width) until hand-tight.



When tighten the rollers, steady the roller bolts with the supplied screwdriver to prevent the roller shafts from being twisted off.

To mount the filament guide:

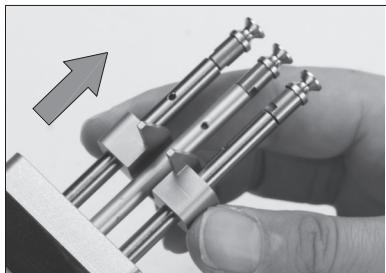

fig. 4.2j

- Slide the filament guide up the Roller shafts in the direction of the arrow.

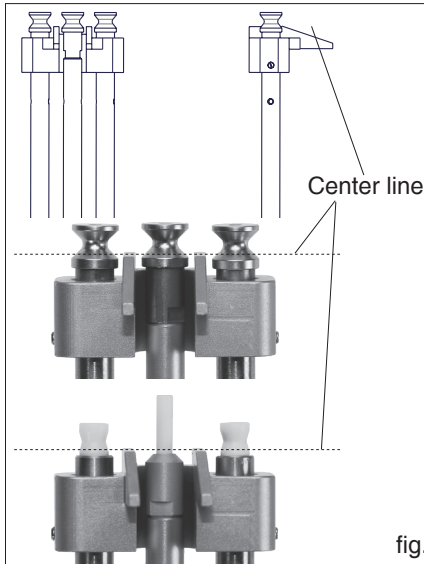

fig. 4.2k

- Push the filament guide upward far enough to ensure that the rollers do not rub against the filament guide and that the process material can slide unhindered into the roller grooves (fig. 4.2k center line).

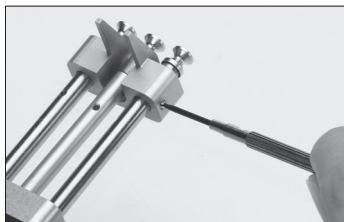

fig. 4.2l

- Tighten the grub screws with the supplied screwdriver (1.5 mm blade width).

5 Cleaning

For cleaning the unit do not use any



AGGRESSIVE SOLVENTS

such as trichloroethylene or similar chemicals.



NO WARRANTY OR LIABILITY

shall be accepted for damage resulting from improper cleaning.

6 Verification interval

The question of finding the right frequency of calibration accuracy verification depends on several different factors:

- Operating time and load of the SCHMIDT tension meter
- Tolerance band defined by the customer
- Changes to the tolerance band compared to previous calibrations

Therefore, the interval between verifications of calibration must be determined by the user's Quality Assurance Department, based on the user's experience.

Assuming normal operating time and load as well as careful handling of the tension meter, we recommend a verification interval of one year.

7 Correspondence

If you have any questions regarding the instrument or instruction manual or their use, please indicate all the following details which are given on the ID plate:

- 1) Model
- 2) Serial number

8 Repairs

Shipping instructions:

We kindly ask for return free of charge for us, if possible by airmail parcel. All occurring charges, if any (such as freight, customs clearance, duty etc.), will be billed to customer.

For return from foreign countries, we ask you to include a proforma invoice with a low value for customs clearance only, e.g. 50 Euro, each and to advise the shipment in advance by fax or eMail.



To avoid unnecessary follow-up questions, and the resulting loss of time or possible misunderstandings, please return the instrument with a detailed fault description to our service department. Please indicate in your order whether you require an Inspection Certificate 3.1 according to DIN EN 10204.

Service address:

**Hans Schmidt & Co GmbH
Schichtstr. 16
D-84478 Waldkraiburg
Germany**

SCHMIDT

control instruments

SCHMIDT-Test-Instruments
indispensable in production monitoring,
quality control and automation
We solve your measuring problems:



Tension Meter



Force Gauge



Torque Meter



Tachometer



Speed- and Lengthmeter



Electronic Lengthmeter



Stroboscope



Screen Printing Tension Meter



Thickness Gauge



Yarn Package Durometer and Shore Durometer



Sample Cutter



Balance



Moisture Meter



Leak Tester

More than 75 years - Worldwide -

Hans Schmidt & Co GmbH

Mailing address:

P. O. B. 1154
84464 Waldkraiburg Germany

Shipping address:

Schichtstr. 16
84478 Waldkraiburg Germany

Phone:

int. + 49 / (0)8638 / 9410-0

Fax:

int. + 49 / (0)8638 / 4825

int. + 49 / (0)8638 / 67898

e-mail:

info@hans-schmidt.com

Internet:

http://www.hans-schmidt.com