



Instruction Manual

Valid as of: 01.04.2006 • Please keep the manual for future reference!



Contents

1	Warranty and liability	3
1.1	Notices within the instruction manual	3
1.2	Responsibilities of the operating company	3
1.3	Responsibilities of the personnel	3
1.4	Informal safety measures	4
1.5	Training of the personnel	4
1.6	Intended use	4
1.7	Dangers in handling the device	4
1.8	Copyright	4
1.9	Declaration of conformity	4
2	Available models	5
2.1	Specifications	5
2.2	Optional accessories	6
2.3	Delivery includes	7
2.4	Unpacking	7
3	Notices before starting measurement	7
3.1	Operating elements of the tension meter	8
3.2	Material thickness compensator	9
3.3	Measuring with the tension meter	10
3.4	Verification of the DN1 calibration	11
3.5	Air damping (optional accessory Code A)	12
4	Service and maintenance	13
4.1	Rollers	13
4.2	Cleaning	13
4.3	Verification intervals	13
4.3.1	Verification of calibration and determination of repair costs	14
5	Correspondence	15
6	Repairs	15

1 Warranty and liability

In principle, the supply of the device is subject to our "General Conditions of Sale and Delivery." These have been provided to the operating company on conclusion of the contract, at the latest.

Warranty:

- SCHMIDT tension meters are warranted for 12 months.

Parts subject to wear, electronic components and measuring springs are not covered by the warranty. No warranty or liability will be accepted for bodily injury or property damage resulting from one or several of the following causes:

- Misuse or abuse of the device.
- Improper mounting, commissioning, operation and maintenance of the device (e.g. verification interval).
- Operation of the device if any safeguards are defective or if any safety and protection precautions are not properly installed or not operative.
- Failure to comply with the notices in the instruction manual regarding transport, storage, mounting, commissioning, operation, maintenance and setup of the device.
- Any unauthorized structural alteration of the device.
- Insufficient inspection of device components that are subject to wear.
- Opening the device or improper repair work.
- Disasters caused by the effects of foreign objects or by force majeure.

1.1 Notices within the instruction manual

The fundamental prerequisite for the safe handling of this device and its troublefree operation is the knowledge of the basic safety notices and safety instructions.

These instruction manual contains the most important notices for the safe operation of the device.

These instruction manual, in particular the safety notices, must be observed by any person who works with the device. In addition, the local valid rules and regulations for the prevention of accidents must be complied with.

The representations within the instruction manual are not true to scale.

The dimensions given are not binding.

General indications of direction, such as FRONT, REAR, RIGHT, LEFT apply when viewing the front of the device.

1.2 Responsibilities of the operating company

In compliance with the EC Directive 89/655/EEC, the operating company agrees to only permit persons to work with the device who:

- are familiar with the basic regulations on industrial safety and accident prevention and who have been trained in handling the device.
- have read and understood the chapter on safety and the warning notices in these instruction manual and have confirmed this with their signatures.
- are examined regularly on their safe and conscientious working method.

1.3 Responsibilities of the personnel

All persons who work with the device agree to perform the following duties before starting work:

- to observe the basic regulations on industrial safety and accident prevention.
- to read the chapter on safety and the warning notices in these instruction manual and to confirm with their signatures that they have understood them.

1.4 Informal safety measures

The instruction manual must always be kept on hand where the device is operated. Apart from the instruction manual, the general and local valid regulations on accident prevention and environmental protection must be provided and complied with.

1.5 Training of the personnel

Only trained and instructed personnel is permitted to work with the device. The responsibilities of the personnel must be clearly defined for mounting, commissioning, operation, setup, maintenance and repair. Trainees may only work with the device under the supervision of an experienced personnel

1.6 Intended use

The device is intended exclusively to be used as a tension meter. Any other use or any use exceeding this intention will be regarded as misuse. Under no circumstances shall Hans Schmidt & Co GmbH be held liable for damage resulting from misuse.

The intended use also includes:

- Complying with all notices included in the instruction manual and observing all inspection and maintenance works.

1.7 Dangers in handling the device

The device was designed according to the state of the art and the approved safety standards. Nevertheless, its use may cause serious or fatal injury to the user or third persons, and/or an impairment of the device or of other material assets.

The device may only be applied:

- For its intended use in a faultless condition with regard to the safety requirements.
- Malfunctions that could impair safety must be remedied immediately.
- Personal protective equipment must be used according to the EC Directive 89/686/EEC.



The device must not be operated in potential explosive areas and must not come into contact with aggressive substances.

1.8 Copyright

The copyright on these instruction manual remains with the company Hans Schmidt & Co GmbH.

These instruction manual is intended for the operating company and its personnel only. They contain instructions and notices that may only be reproduced on the prior written permission of

Hans Schmidt & Co GmbH

and under indication of the complete reference data. Violations will be prosecuted.

1.9 Declaration of conformity

Our mechanical tension meters do not belong to the EC machinery directive 2006/42/EC and do not have a CE mark.

2 Available models



These instruction manual refer to model DN1 of the DN series.

The individual models of the DN series are also available with the following modifications (customized versions):

- Special tension ranges
- Customized measuring head width for applications with limited access space
- Customized distance between the two outer guide rollers to minimize deflection of the material
- Calibration for material path other than standard (vertical)
- Calibration to different units of measure, such as g or kg

Model	Tension Range cN	*Measuring Head Width mm	**SCHMIDT Calibration Material	Material Thickness Compensator Included
DN1-120	20 - 120	65	PA: 0.12 mm Ø	
DN1-200	20 - 200	65	PA: 0.12 mm Ø	
DN1-400	20 - 400	65	PA: 0.20 mm Ø	
DN1-1000	50 - 1000	65	PA: 0.30 mm Ø	yes
DN1-2000	200 - 2000	116	PA: 0.50 mm Ø	yes
DN1-3500	400 - 3500	116	PA: 0.80 mm Ø	yes
DN1-5000	400 - 5000	116	PA: 0.80 mm Ø	yes
DN1-8000	500 - 8000	116	PA: 1.00 mm Ø	yes
DN1-10K	2 - 10 daN	116	PA: 1.00 mm Ø	yes
DN1-20K-L	5 - 20 daN	216	PA: 1.50 mm Ø	yes
DN1-30K-L	5 - 30 daN	265	PA: 1.50 mm Ø	
DN1-50K-L	5 - 50 daN	265	Steel rope 1.50 mm Ø (7 x 7 x 0.20)	

* Depending on model, either width of filament guide or outer distance between outside guide rollers.

** Suitable for 95% of applications. PA = Polyamide Monofilament
If the material to be measured differs significantly from the SCHMIDT calibration material in diameter, rigidity, shape, etc., we recommend calibration using custom-er material. For this purpose, a material sample of about 5 m should be supplied.

International unit for tension force: 1 cN = 1.02 g = 0.01 N

1 daN = 1.02 kg = 10.0 N

2.1 Specifications

Calibration: According to SCHMIDT factory procedure

Accuracy: ± 1% full scale (FS) or
± 1 graduation on scale

Scale diameter: 54 mm

Temperature range: 10 - 45°C

Air humidity: 85% RH, max.

Housing material: Die-cast aluminium

Housing dimensions: 220 x 74 x 42 mm (L x W x H)

Weight net (gross): Up to DN1-10K approx. 700 g (1200 g)
DN1-20K-L and higher approx. 900 g (2200 g)

2.1 Specifications (cont.)

Guide rollers:

V-grooved	Line Speed m/min max.	Roller Material
Standard	2000	Hard-coated aluminium
Code K	3500	Hard-coated aluminium
Code H	5000	plasma-coated aluminium (not for Type DN1-30K-L and DN1-50K-L)
Code T	1000	Plastic (POM) black
Code W	1000	Nickel-plated steel
Code ST	1000	hardened steel
Code B	1000	Tempered steel, especially for measuring tyre record
Code CE2	1000	Aluminium ceramic-coated
Asymetrische Nut Code ASY	1000	Hard-coated aluminium - Design is without filament guide
Asymetrische Nut Code ASYB	1000	Tempered steel, - Design is without filament guide
Code V1	1000	Hard-coated aluminium (only for Model DN1-30K and DN1-50-K)
U-grooved Code U	2000	Hard-coated aluminium

2.2 Optional accessories

Code A:



Air damping

(available for Models DN1-120 to DN1-5000)

Recommended for applications in which great fluctuations of the measured tension occur (as in spooling and winding machines).

Code L:



Special lever

Recommended for Model DN1-10K and higher ranges (standard for Model DN1-20K-L and higher).

Facilitates acquisition of the running material by reducing the effort necessary to extend the outer rollers.

2.3 Delivery includes

- Tension meter
- Hex key (with Code **A**, dashpot with hex-head screw)
- Certificate of Compliance with the order 2.1 under EN 10204
- Instruction manual
- Carrying case

2.4 Unpacking

Unpack the tension meter and inspect it for any shipping damage.

Notices of defect must be announced immediately, at the latest within 7 days on receipt of the goods.

3 Notices before starting measurement



Have you read and understood the instruction manual, in particular chapter 1 “Warranty and liability” ?

You are not permitted to operate the device before doing so.

Before working with the device you must put on your personal protective clothing, if necessary. For example, eye protectors, gloves, etc.

Tensions that exceed the tension range of the instrument by more than 100 % may cause permanent damage to the movement and must be avoided under any circumstances.

1 The ID plate with the serial number as well as the calibration label (optional) are provided on the bottom of the instrument, the SCHMIDT Quality Seal are provided on the surface.

Calibration label (option)

ID plate with serial number

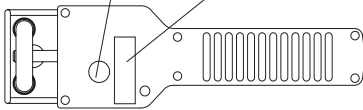

SCHMIDT - quality seal

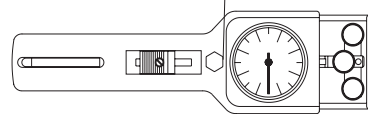
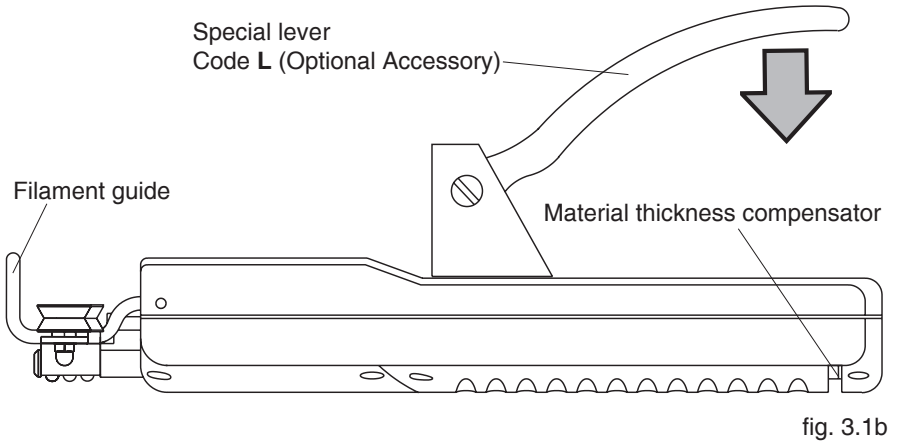
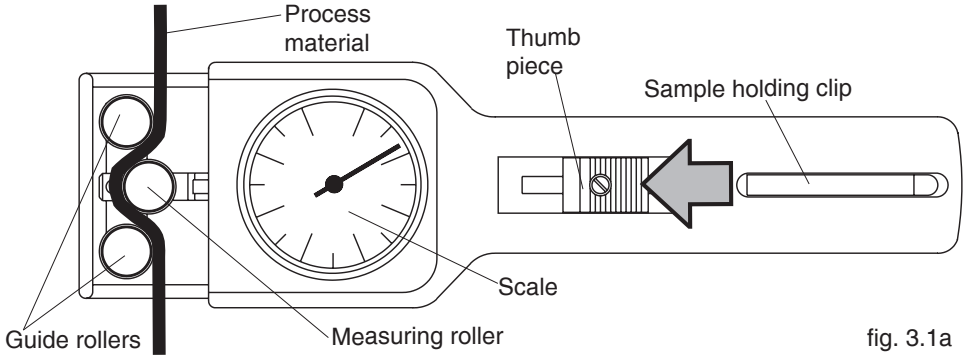

fig. 3

3.1 Operating elements of the tension meter



3.2 Material thickness compensator

(Only used at instruments with material thickness compensator)

The 3-roller system for tension measurement relies on the displacement of the middle roller to give an indication of the line tension. As the material thickness changes, there will be a change in the tension reading, even when the line tension has not changed. To compensate for this effect, high-range instruments are usually equipped, as necessary, with a material thickness compensator which automatically shifts the outer rollers. Insert a sample of the material to be measured, or any other sample that has the same diameter, in the material thickness compensator.

To determine whether the material thickness compensator needs to be used for a specific application, we recommend to check the calibration with and without process material in the material thickness compensator (chapter 3.4).

Use of the material thickness compensator

Thick process material

Thin process material

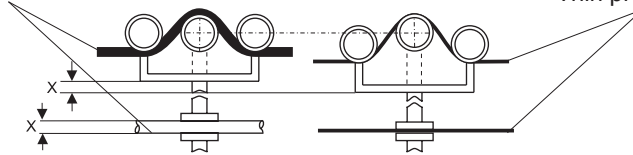

fig. 3.2a

X= Offset of the outer rollers caused by different material diameter

Inserting the process material

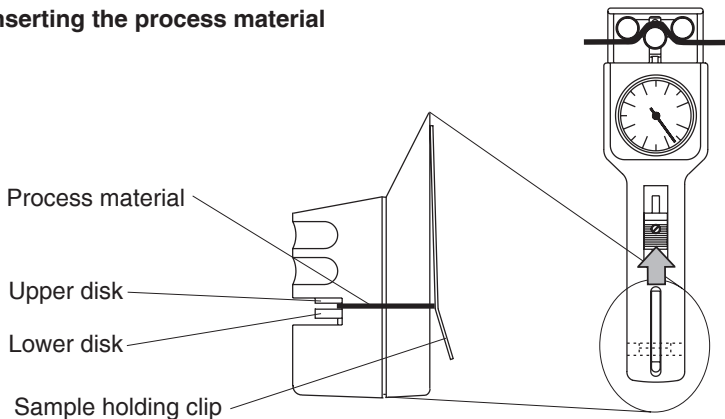

fig. 3.2c

- Push the thumb piece or special lever as far as it will go in the direction indicated by the arrow.
- Place the process material in the opening between the upper disk and the lower disk of the material thickness compensator.
- Secure the process material ends under the sample holding clip.
- **Slowly** let the thumb piece or special lever **slide return** into its original position.

It is important to assure that the process material runs smoothly between the guide rollers and the measuring roller.



It is essential that the thumb piece return slowly to its initial position. Any uncontrolled snap-back may affect calibration and may also damage the instrument.



It is important to assure that the process material lies precisely between the instrument's two visible disk-like anvil surfaces of the material thickness compensator.

3.3 Measuring with the tension meter

Requirement:

If necessary, a sample of the material to be measured must be inserted in the thickness compensator as described in chapter 3.2.

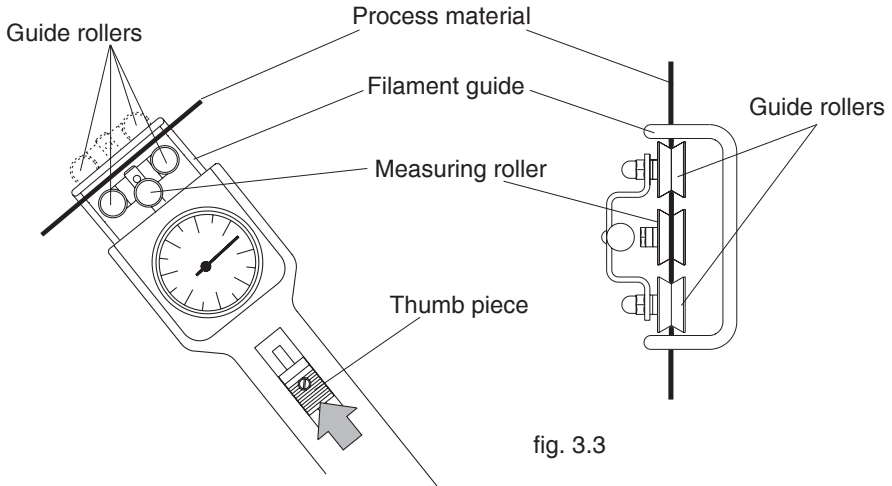

Inserting:

- Push the thumb piece or special lever as far as it will go in the direction of the arrow to extend the outer rollers.
- Keeping the outer rollers extended, bring the instrument behind or under the filament and move it so that the filament guide bars contact the process material (fig. 3.3).
- **Slowly** release pressure on the thumb piece until the outer rollers return to their original position.

It is important to assure that the process material runs smoothly between the guide rollers and the measuring roller.



It is essential that the thumb piece return slowly to its initial position. Any uncontrolled snap-back may affect calibration and may also damage the instrument.

The scale pointer will now show the line tension directly.

Removing:

- Push the thumb piece or special lever as far as it will go in the direction of the arrow.
- With the outer rollers extended, move the instrument away from the material.
- Slowly release pressure on the thumb piece until the outer rollers return to their original position.

3.4 Verification of the DN1 calibration

All tension meters are calibrated with standard materials - such as polyamide monofilament (PA) - according to the SCHMIDT factory procedure.

The filament sizes are noted in chapter 2.

Any difference in process material size and rigidity from the standard material may cause a deviation of the accuracy.

In 95 % of all industrial applications the SCHMIDT calibration has been proven to provide the best results and is used for comparative purposes.

If the process material differs significant in size, rigidity and shape we recommend special calibration using customer`s sample. For this purpose a material sample of 5 m should be supplied.

Requirement:

If necessary, a sample of the material to be measured must be inserted in the thickness compensator as described in chapter 3.2

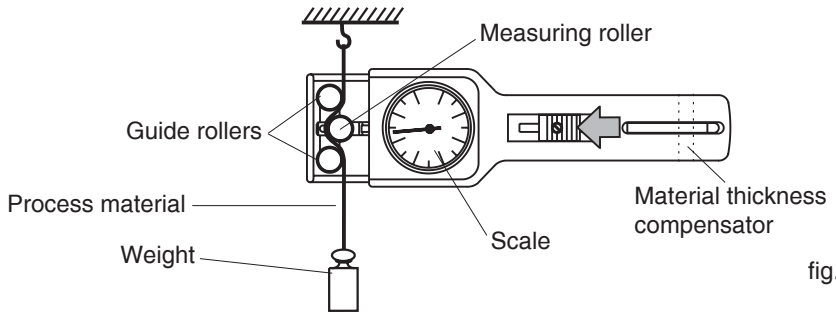

fig. 3.4

- Suspend a known weight that corresponds to the tension to be measured (pay attention to the correct unit of measure) from the Process material, vertically, as shown in fig. 3.4. (Always use a fresh portion of the material to be measured).
- Push the thumb piece as far as it will go in the direction indicated by the arrow and thread the material to be measured between the guide rollers and the measuring roller. Refer to chapter 3.3.
- Slowly release pressure on the thumb piece until the outer rollers return to their original position.



It is essential that the thumb piece return slowly to its initial position. Any uncontrolled snap-back may affect calibration and may also damage the instrument.

- Before the final check, move the instrument slowly up and down to compensate any friction caused by the instrument and thus ensure the repeatability.

- The tension value should be equal to the value of the suspended weight.

If this procedure shows a deviation beyond the allowable tolerance and a reliable operation is no longer allowed, the instrument has to be recalibrated or repaired.

For recalibration, return the tension meter to the factory.

3.5 Air damping (optional accessory Code A)

During operation, as in spooling or winding machines, high frequency tension fluctuation can occur. This process fluctuation can result in rapid pointer swings which make it difficult to read the scale. This effect can be reduced by using the built in Air Dashpot Damping mechanism. The dashpot is infinitely variable and ensures the best readable pointer results with minimum pointer swings. The air dashpot is built in during production of the tension meter and can therefore not be retrofitted.

Setscrew (inside Housing)

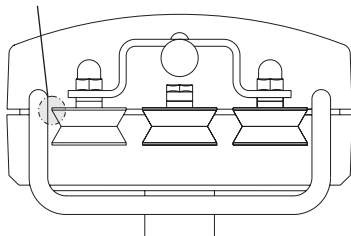

fig. 3.5

- 1** Turn setscrew clockwise = Increase damping
Turn setscrew counterclockwise = Decrease damping

Setting the dashpot:

- Screw in the setscrew clockwise as far as it will go = maximum possible damping. The screw is protected against overwinding. The damping is now at its maximum setting.
- Turn the setscrew counterclockwise until the desired damping of the pointer is reached, and the pointer swings are minimal.
The setting range is three counterclockwise revolutions, starting from the maximum setting.



Do not screw out the setscrew by more than 5 counterclockwise revolutions; the setscrew may otherwise fall into the tension meter housing.

4 Service and maintenance

The tension meter is easy to maintain. Depending on operating time and load, the tension meter should be checked according to the locally valid regulations and conditions (as described in chapter 3.4).

Other testing methods as described in chapter 3.4 can cause different measuring readings.

4.1 Rollers

You should regularly inspect the rollers to assure that they are running easily and smoothly. You can replace the rollers yourself, as necessary. When ordering spare rollers, please indicate the tension meter model and the serial number (on the rear side of the tension meter).

e. g.

Ordering of spare rollers

Model:	DN1-1000 (on the rear of the tension meter)
Serial number:	240 - 888888 (on the rear of the tension meter)
Standard rollers:	Order number R524004 (up to 20 daN) Order number R524013-30 (30 daN/50 daN)
Supply:	1 set (3 pieces) spare rollers 2000 m/min with mounting wrench or
Model:	DN1-1000-K (on the rear of the tension meter)
Serial number:	Z 240 - 888888 (on the rear of the tension meter)
Roller Code K :	Order number R524003
Supply:	1 set (3 pieces) spare rollers 3500 m/min with mounting wrench

4.2 Cleaning

For cleaning the unit, do not use any



AGGRESSIVE SOLVENTS

such as trichloroethylene or similar chemicals.



NO WARRANTY OR LIABILITY

shall be accepted for damage resulting from improper cleaning.

4.3 Verification intervals

The question of finding the right frequency of calibration accuracy verification depends on several different factors:

- ➔ Operating time and load of the SCHMIDT tension meter
- ➔ Tolerance band defined by the customer
- ➔ Changes of the tolerance band compared to previous verifications of calibration

Therefore, the interval between verifications must be determined by the user's Quality Assurance Department based on the user's experience.

Assuming normal operating time and load as well as careful handling of the tension meter, we recommend a verification interval of 1 year.

4.3.1 Verification of calibration and determination of repair costs

Flow chart for verifying the calibration of used tension meters, incoming and outgoing verification with Inspection Certificate 3.1 according to DIN EN 10204

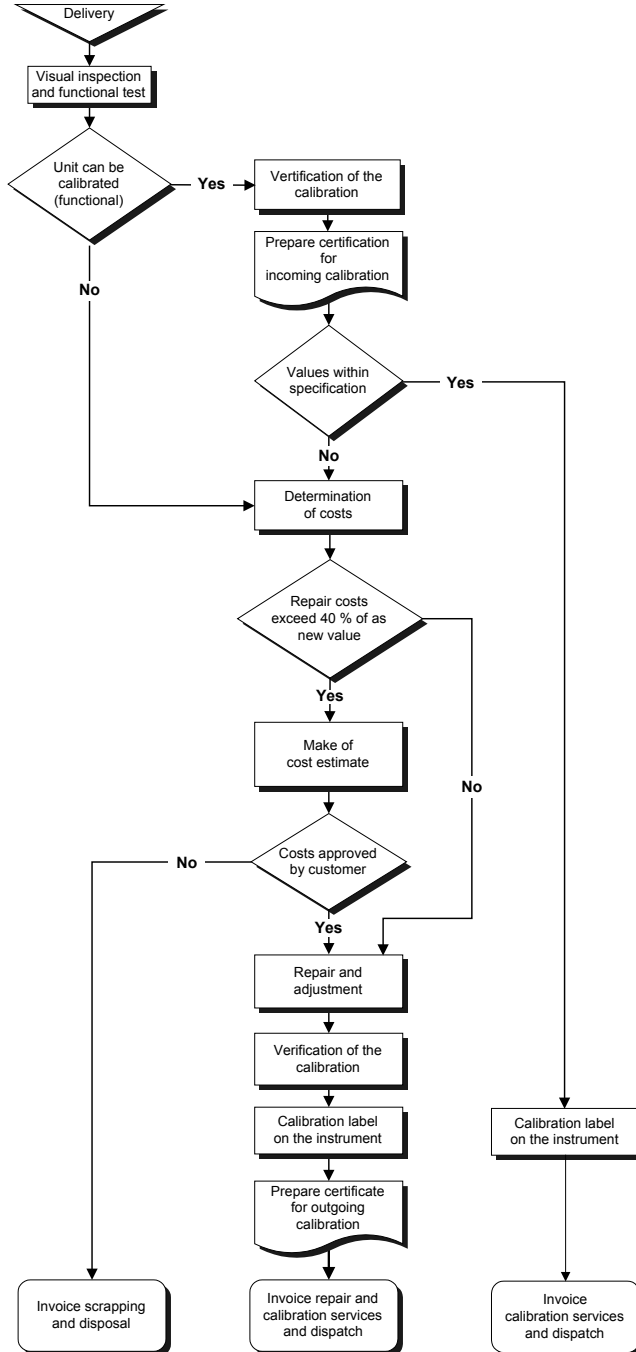

5 Correspondence

Should you have any questions regarding the tension meter or instruction manual, or their use, please indicate above all the following details which are given on the ID plate:

- 1) The tension meter model
- 2) The serial number

6 Repairs

Shipping instructions:

We kindly ask for return free of charge for us, if possible by airmail parcel. All occurring charges, if any (such as freight, customs clearance, duty, etc.) will be billed to customer. For return from foreign countries, we ask you to include a proforma invoice with a low value for customs clearance only, e.g. 50 Euro, each and to advise the shipment in advance by fax or eMail.



To avoid unnecessary follow-up questions, and the resulting loss of time or possible misunderstandings, please return the tension meter with a detailed fault description to our service department. Please indicate in your order whether you require an Inspection Certificate 3.1 according to DIN EN 10204.

Service address:

**Hans Schmidt & Co GmbH
Schichtstr. 16
D-84478 Waldkraiburg
Germany**

Notes:

SCHMIDT

control instruments

SCHMIDT-Test-Instruments
*indispensable in production monitoring,
quality control and automation*
We solve your measuring problems:



Tension Meter



Force Gauge



Torque Meter



Tachometer



Speed- and Lengthmeter



Electronic Lengthmeter



Stroboscope



Screen Printing Tension Meter



Thickness Gauge



Yarn Package Durometer and Shore Durometer



Sample Cutter



Balance



Moisture Meter



Leak Tester

More than 75 years - Worldwide -

Hans Schmidt & Co GmbH

Mailing address:

P. O. B. 11 54
84464 Waldkraiburg Germany

Shipping address:

Schichtstr. 16
84478 Waldkraiburg Germany

Phone:

int. + 49 / (0)8638 / 9410-0

Fax:

int. + 49 / (0)8638 / 4825

int. + 49 / (0)8638 / 67898

e-mail:

info@hans-schmidt.com

Internet:

<http://www.hans-schmidt.com>