

Force Gauge PSH

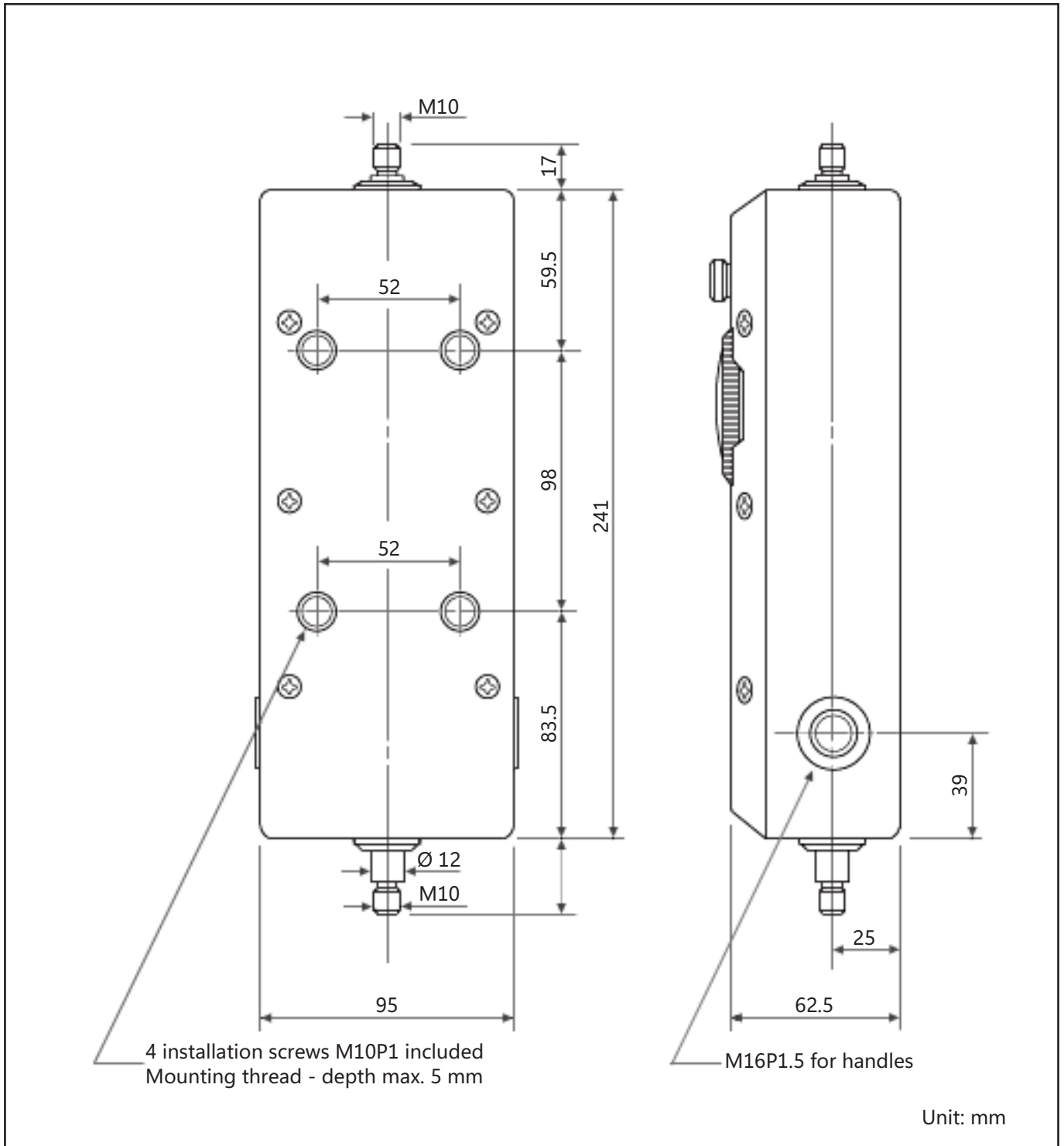

Specifications subject to change without notice!