

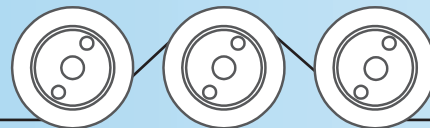









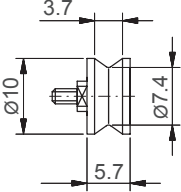

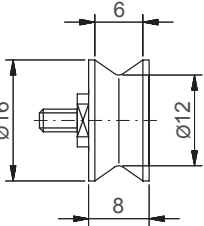

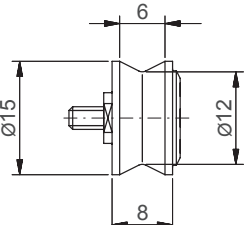

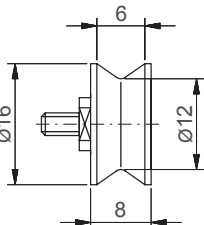
Führungsrollen- Katalog

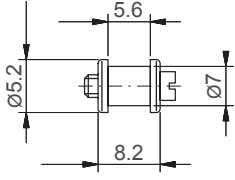

Rollensätze

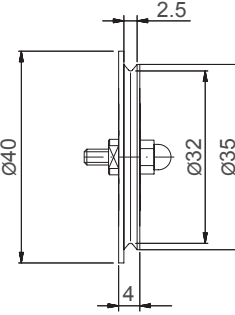
Bestell-Nr.	Typen	Beschreibung	Bild	Abmessungen
R521105 R515405 R515405-1000 R516505 R516605 R516605-1000 R580005 R559405 R559505 R559605 R559705 R592405 R592505 R569005 R569104	ZF2 DXE (bis 400 cN) DXE (ab 1000 cN) DXV DXES (bis 400 cN) DXES (ab 1000 cN) ZEF DTEB DTEX DTVB DTVX DTSE DTXE MAZF MBZF	Aluminium hardcoated Durchlauf- geschwindigkeit 900 m/min geeignet für Garne, Fäden, dünne Drähte		
R521204 R515004 R524004 R515204 R581004 R557004 R558004 R592004 R592104 R569204 R569304	ZD2 DX2 DN1 (bis 20K) DX2S ZED DTMB DTMX DTS DTX MAZD MBZD	Aluminium hardcoated Durchlauf- geschwindigkeit 2000 m/min geeignet für Garne, Fäden, dünne Drähte		
R530113 R523013 R530013 R524013-30	MKM Q MK DN1 (30K/50K)	Aluminium hardcoated Durchlauf- geschwindigkeit 1000 m/min geeignet für Garne, Fäden, dünne Drähte		
R560007 R562107 R562107-200 R563107 R563107-200	TS1 FS1 (bis 100 cN) FS1 (ab 200 cN) FS1-422 (bis 100 cN) FS1-422 (ab 200 cN)	Aluminium hardcoated Durchlauf- geschwindigkeit 2000 m/min geeignet für Garne, Fäden, dünne Drähte		

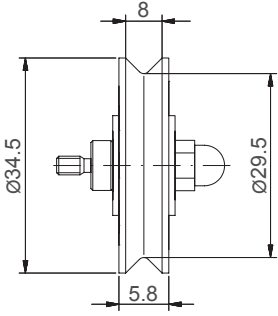
Rollensätze

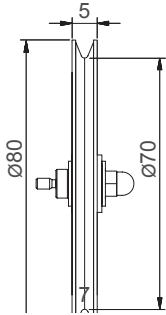

Bestell-Nr.	Typen	Beschreibung	Bild	Abmessungen
R515512 R560512 R562212 R562212-500 R563212 R563212-500	DXP TSP FSP (bis 200 cN) FSP (ab 500 cN) FSP-422 (bis 200 cN) FSP-422(ab 500 cN)	Oxidkeramik Durchlaufgeschwindigkeit 6000 m/min geeignet für Fäden, Garne		
R515911 R516411 R559211 R559311 R592611 R592711 R563011 R562411 R562411-500 R563411 R563411-500	DXF DXFS DTFB DTFX DTSF DTXF TSL FSL (bis 200 cN) FSL (ab 500 cN) FSL-422 (bis 200 cN) FSL-422 (ab 500 cN)	Aluminium hardcoated Durchlaufgeschwindigkeit 4000 m/min geeignet für Lichtleitfasern, Carbonfasern, technische Fasern		
R516026 R592826 R592926 R561026 R562326 R563326	DXL DTSL DTXL TSH FSH FSH-422	Stahl gehärtet Durchlaufgeschwindigkeit 4000 m/min geeignet für Drähte, Kabel, Buffer Tubes		
R564045	TSF	Aluminium hardcoated Durchlaufgeschwindigkeit 5000 m/min geeignet für Lichtleitfasern, empfindliche Fasern		

Technische Änderungen vorbehalten.

Rollensätze



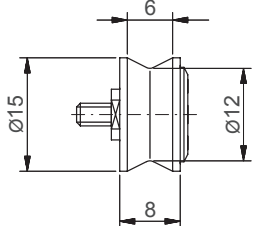

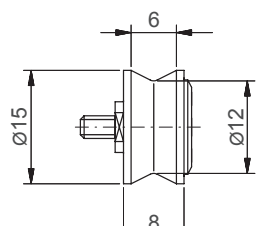
Bestell-Nr.	Typen	Beschreibung	Bild	Abmessungen
R540017 R540517 R542017 R542117	ETB (S/N 400xxxx) ETX (S/N 405xxxx) ETB (S/N 420xxxx bis 500 cN) ETX (S/N 421xxxx bis 500 cN)	Aluminium hart verchromt Durchlauf- geschwindigkeit 2000 m/min geeignet für Fäden, Garne		
R540020 R540520 R542020 R542120	ETPB (S/N 400xxxx) ETPX (S/N 405xxxx) ETPB (S/N 420xxxx) ETPX (S/N 421xxxx)	Oxidkeramik Durchlauf- geschwindigkeit 6000 m/min geeignet für Fäden, Garne		
R561142 R562742 R563742	TSW FSW FSW-422	Aluminium hardcoated Durchlauf- geschwindigkeit 2000 m/min geeignet für Drähte, Seile, Kabel		
R521127 R515427 R515427-1000 R516527 R516627 R516627-1000 R580027 R559427 R559527	ZF2 DXE (bis 400 cN) DXE (ab 1000 cN) DXV DXES (bis 400 cN) DXES (ab 1000 cN) ZEF DTEB DTEX	Code W Stahl vernickelt Durchlauf- geschwindigkeit 450 m/min geeignet für Drähte		
R521128 R515428 R515428-1000 R516528 R516628 R516628-1000 R580028 R559428 R559528	ZF2 DXE (bis 400 cN) DXE (ab 1000 cN) DXV DXES (bis 400 cN) DXES (ab 1000 cN) ZEF DTEB DTEX	Code T Kunststoff (POM) schwarz Durchlauf- geschwindigkeit 450 m/min geeignet für Fasern, Garne		

Rollensätze

Bestell-Nr.	Typen	Beschreibung	Bild	Abmessungen
R521224 R515024 R523024 R530024 R524024 R524024-30 R515224 R581024 R557024 R558024 R592024 R592124 R560024 R562124 R562124-200 R563124 R563124-200	ZD2 DX2 Q MK DN1 (bis 20K) DN1 (30K/50K) DX2S ZED DTMB DTMX DTS DTX TS1 FS1 (bis 100 cN) FS1 (ab 200 cN) FS1-422 (bis 100 cN) FS1-422 (ab 200 cN)	Code W Stahl vernickelt Durchlauf- geschwindigkeit 1000 m/min geeignet für Drähte		
R521225 R515025 R523025 R530025 R524025 R524025-30 R515225 R581025 R557025 R558025 R592025 R592125 R560025 R562125 R562125-200 R563125 R563125-200	ZD2 DX2 Q MK DN1 (bis 20K) DN1 (30K/50K) DX2S ZED DTMB DTMX DTS DTX TS1 FS1 (bis 100 cN) FS1 (ab 200 cN) FS1-422 (bis 100 cN) FS1-422 (ab 200 cN)	Code T Kunststoff (POM) schwarz Durchlauf- geschwindigkeit 1000 m/min geeignet für Fasern, Garne		

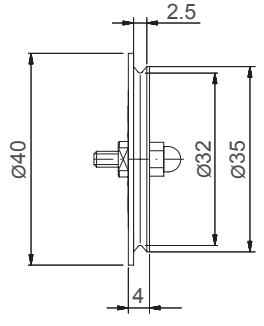

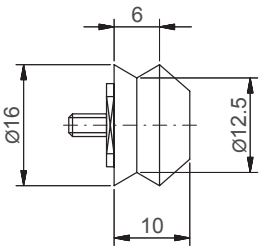
Technische Änderungen vorbehalten.

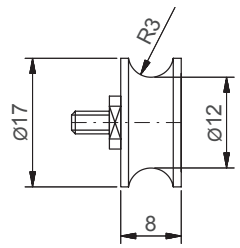
Rollensätze

Bestell-Nr.	Typen	Beschreibung	Bild	Abmessungen
R515910 R516410 R559210 R559310 R592610 R592710 R563010 R562410 R562410-200 R563410 R563410-200	DXF DXFS DTFB DTFX DTSF DTXF TSL FSL (bis 200 cN) FSL (ab 500 cN) FSL-422 (bis 200 cN) FSL-422 (ab 500 cN)	Code T Kunststoff (PVC) rot Durchlaufgeschwindigkeit 4000 m/min geeignet für Lichtleitfasern, Carbonfasern, technische Fasern		
R521216 R515016 R524016 R515216 R581016 R557016 R558016 R592016 R592116 R560016 R562116 R562116-200 R563116 R563116-200	ZD2 DX2 DN1 (bis 20K) DX2S ZED DTMB DTMX DTS DTX TS1 FS1 (bis 100 cN) FS1 (ab 200 cN) FS1-422 (bis 100 cN) FS1-422 (ab 200 cN)	Code H Aluminium plasmabeschichtet Durchlaufgeschwindigkeit 5000 m/min geeignet für Drähte, Fasern, Garne		
R515009 R524009 R524009-30 R515209 R557009 R558009 R592009 R592109 R560009 R562109 R563109	DX2 DN1 (bis 20K) DN1 (30K/50K) DX2S DTMB DTMX DTS DTX TS1 FS1 FS1-422	Code U Aluminium hardcoated Durchlaufgeschwindigkeit 2000 m/min geeignet für dünne Kabel, Drähte, Fasern, Garne		



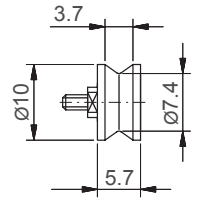

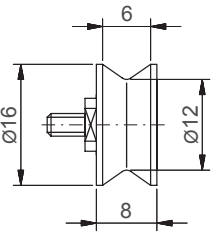
Technische Änderungen vorbehalten.

Rollensätze

Bestell-Nr.	Typen	Beschreibung	Bild	Abmessungen		
R521106	ZF2					
R515406	DXE (bis 400 cN)					
R515406	DXE (ab 1000 cN)					
R516506	DXV					
R516606	DXES (bis 400 cN)	Code K				
R516606	DXES (ab 1000 cN)					
R580006	ZEF	Aluminium hardcoated				
R542006	ETB (S/N 420xxxx ab 1000 cN)	Durchlauf- geschwindigkeit 2000 m/min				
R542106	ETX (S/N 421xxxx ab 1000 cN)					
R559406	DTEB	geeignet für Drähte, Fasern, Garne				
R559506	DTEX					
R559606	DTVB					
R559706	DTVX					
R592406	DTSE					
R592506	DTXE					
R569006	MAZF					
R569106	MBZF					
R521203	ZD2					
R515003	DX2					
R524003	DN1 (bis 20K)					
R524003-30	DN1 (30K/50K)	Code K				
R515203	DX2S	Aluminium hardcoated				
R581003	ZED	Durchlauf- geschwindigkeit 3500 m/min				
R557003	DTMB					
R558003	DTMX					
R592003	DTS	geeignet für Drähte, Fasern, Garne				
R592103	DTX					
R560003	TS1					
R562103	FS1 (bis 100 cN)					
R562103-200	FS1 (ab 200 cN)					
R563103	FS1-422 (bis 100 cN)					
R563103-200	FS1-422 (ab 200 cN)					
R569203	MAZD					
R569303	MBZD					

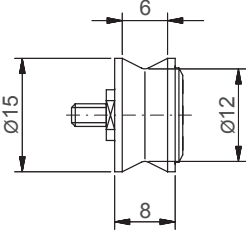

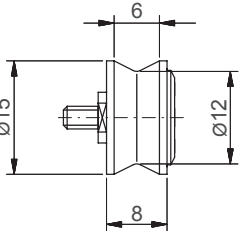

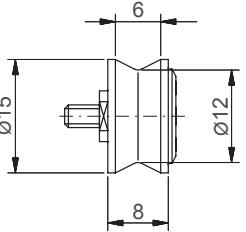
Technische Änderungen vorbehalten.

Rollensätze

Bestell-Nr.	Typen	Beschreibung	Bild	Abmessungen
R521219 R515019 R524019 R524019-30 R515219 R581019 R557019 R558019 R592019 R592119 R560019 R562119 R562119-200 R563119 R563119-200	ZD2 DX2 DN1 (bis 20K) DN1 (30K/50K) DX2S ZED DTMB DTMX DTS DTX TS1 FS1 (bis 100 cN) FS1 (ab 200 cN) FS1-422 (bis 100 cN) FS1-422 (ab 200 cN)	Code CE2 Aluminium keramikbe- schichtet Durchlauf- geschwindigkeit 1000 m/min geeignet für Fasern, Garne		
R515001 R524001 R524001-30 R515201 R557001 R558001 R592001 R592101 R560001 R562101 R562101-200 R569101 R569101-200	DX2 DN1 (bis 20K) DN1 (30K/50K) DX2S DTMB DTMX DTS DTX TS1 FS1 (bis 100 cN) FS1 (ab 200 cN) FS1-422 (bis 100 cN) FS1-422 (ab 200 cN)	Code B Stahl vergütet Durchlauf- geschwindigkeit 1000 m/min geeignet für Reifencord, Sägedraht, hochfeste Stahldrähte		
R521215 R515015 R524015 R524015-30 R515215 R557015 R558015 R592015 R592115 R560015 R562115 R562115-200 R563115 R563115-200	ZD2 DX2 DN1 (bis 20K) DN1 (30K/50K) DX2S DTMB DTMX DTS DTX TS1 FS1 (bis 100 N) FS1 (ab 200 N) FS1-422 (bis 100 N) FS1-422 (ab 200 N)	Code ST Stahl gehärtet Durchlauf- geschwindigkeit 1000 m/min geeignet für Stahldraht, Sägedraht		

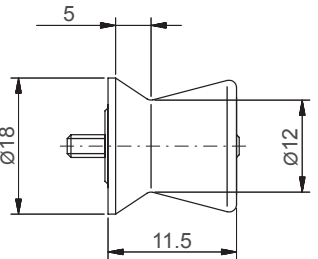

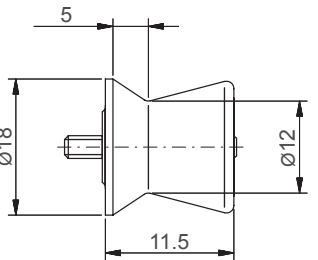

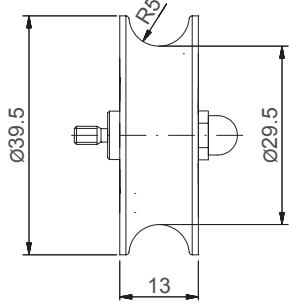

Technische Änderungen vorbehalten.

Rollensätze

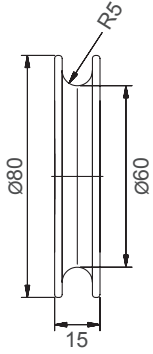
Bestell-Nr.	Typen	Beschreibung	Bild	Abmessungen
R515002 R524002 R524002-30 R524402 R515202 R557002 R558002 R592002 R592102 R560002 R562102 R563102	DX2 DN1 (bis 20K) DN1 (30K/50K) DNW DX2S DTMB DTMX DTS DTX TS1 FS1 FS1-422	Code ASY Aluminium hardcoated Durchlauf- geschwindigkeit 1000 m/min geeignet für Faserbündel		
R515023 R524023 R524023-30 R515223 R557023 R558023 R592023 R592123 R560023 R562123 R563123	DX2 DN1 (bis 20K) DN1 (30K/50K) DX2S DTMB DTMX DTS DTX TS1 FS1 FS1-422	Code ASYB Stahl vergütet Durchlauf- geschwindigkeit 1000 m/min geeignet für Faserbündel		
R516035 R557535 R558535 R592835 R592935 R561035 R562335 R563335	DXL DTLB DTLX DTSL DTXL TSH FSH FSH-422	Code R1 Stahl hart verchromt Durchlauf- geschwindigkeit 4000 m/min geeignet für Kabel, Licht- leitkabel		

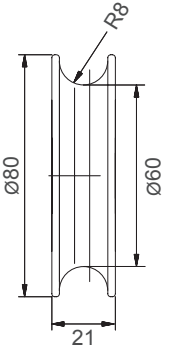
Technische Änderungen vorbehalten.

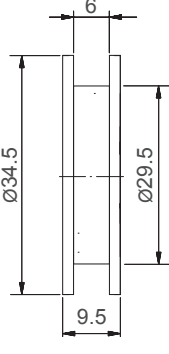
Rollensätze

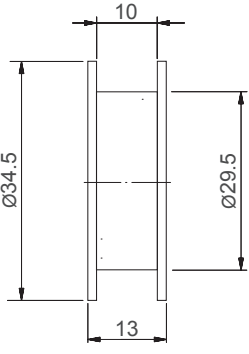
Bestell-Nr.	Typen	Beschreibung	Bild	Abmessungen
R561143 R562743 R563743	TSW FSW FSW-422	Code R2 Aluminium hardcoated Durchlauf- geschwindigkeit 2000 m/min geeignet für Drähte, Seile, Kabel		
R561144 R562744 R563744	TSW FSW FSW-422	Code R3 Aluminium hardcoated Durchlauf- geschwindigkeit 2000 m/min geeignet für Drähte, Seile, Kabel		
R592840 R592940 R561040 R562340 R563340	DTSL DTXL TSH FSH FSH-422	Code B6 Stahl gehärtet Durchlauf- geschwindigkeit 2000 m/min geeignet für flache Materialien		
R592841 R592941 R561041 R562341 R563341	DTSL DTXL TSH FSH FSH-422	Code B10 Stahl gehärtet Durchlauf- geschwindigkeit 2000 m/min geeignet für flache Materialien		

Technische Änderungen vorbehalten.

Einzelrollen

Bestell-Nr.	Typen	Beschreibung	Bild	Abmessungen
R12900 (innen) R12902 (außen)	DN1 (20K bis 50K) DTS-60K-V1 DTX-60K-V1	Code V 1 Aluminium hardcoated Durchlauf- geschwindigkeit 1000 m/min geeignet für Stahlseile		

Technische Änderungen vorbehalten.

Hans Schmidt & Co GmbH

Postfach 1154
84464 Waldkraiburg Germany

Telefon: int. + 49 / (0)8638 / 9410-0
Fax: int. + 49 / (0)8638 / 4825

e-mail: info@hans-schmidt.com
Internet: http://www.hans-schmidt.com