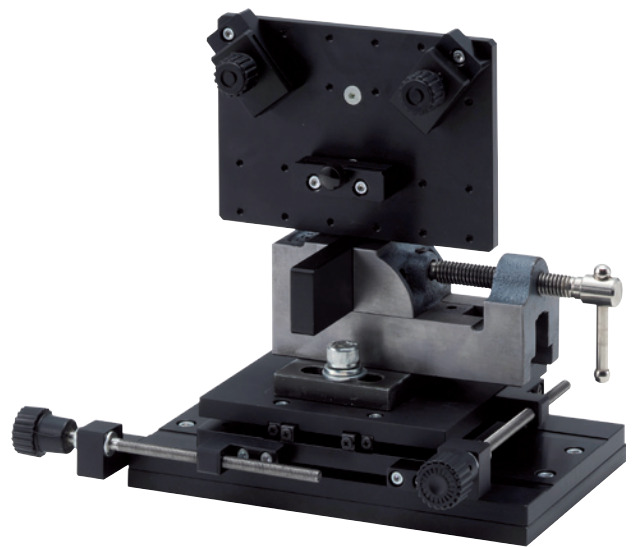

Table SJS-100N

For pull and shear tests on soldered
electronic components



SJS-100N-L



SJS-100N-S

Feature

- The tables allow precise placement of the sample.
- Circuit boards can be mounted on the tables for testing the strength of solder joints.
- The table angle is adjustable between 45 and 90 degrees.
- Measurements according to different standards can be executed with hooks and pins of SJ series.

Applications

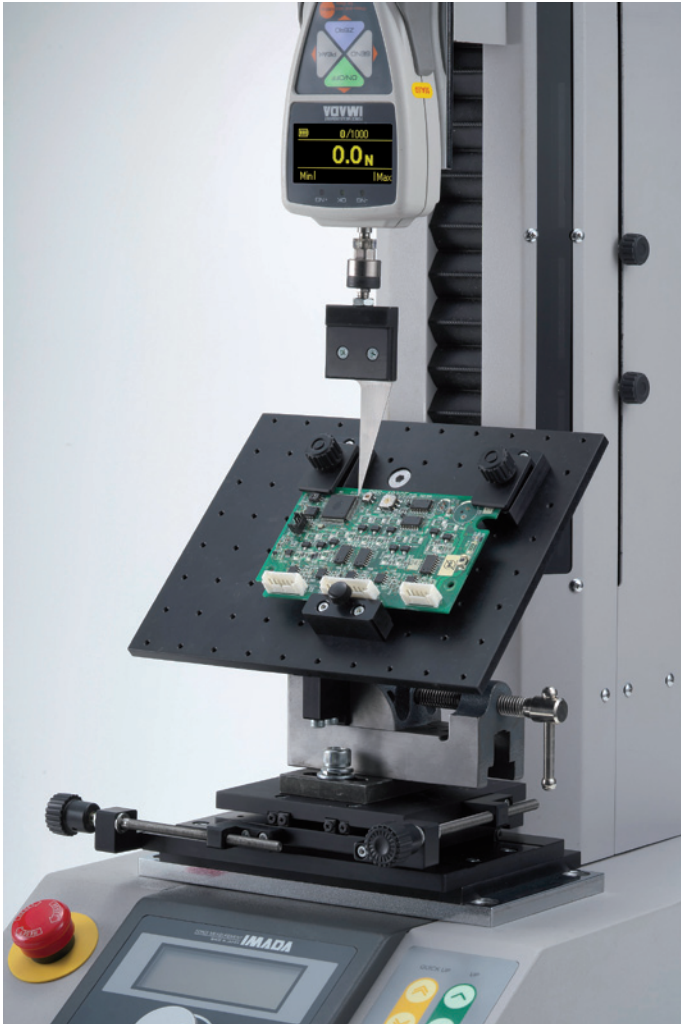

Note

- Combining with a test stand, more stable measuring becomes possible.
- All information is subject to change without prior notice.

Specifications

Model	SJS-100N-L	SJS-100N-S
Application	Large samples	Small samples
Capacity	100 N	
Weight	Approx. 3.2 kg	Approx. 2.8 kg
Max. moving distance	± 30 mm	

Dimensional drawing

SJS-100N-L

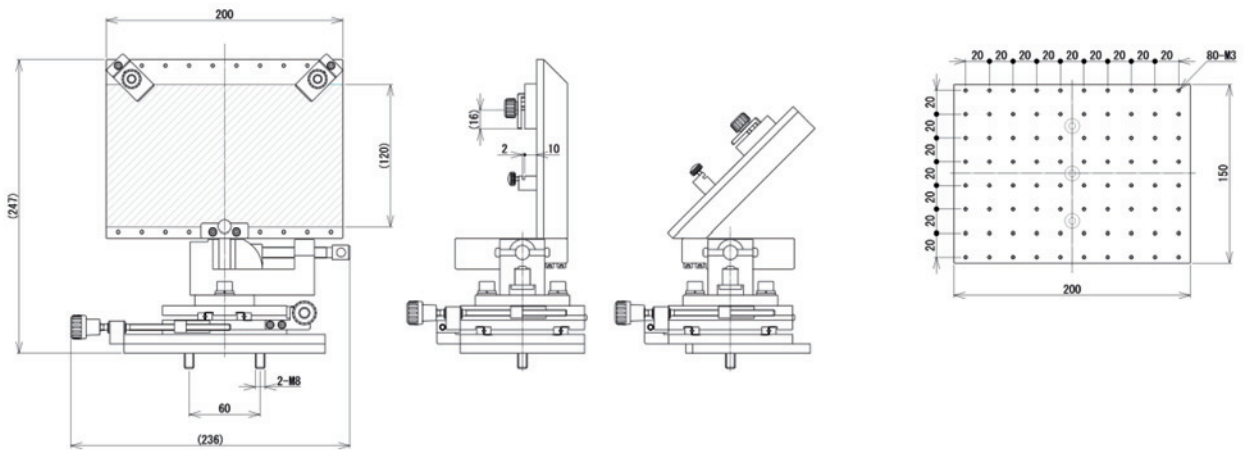

SJS-100N-S

